

18,623-1



DATE: January 12, 2024  
QUOTE #:325768-01

FILED FOR RECORD  
at 2:00 o'clock P M

FEB 13 2024

HUNT COUNTY PCT 4 ATTN AUDITOR  
STEVE HARRISON

Pemberton, Brent  
817.219.6187

One (1) New Caterpillar Inc Model: 299D XPS  
Includes: Rooftop Cooler + 80" Bolt-On-Cutting Edge Bucket  
Also Include: Operating Kit for Boom Mower + Debris Kit + 80" Grapple Bucket  
By BECKY LANDRUM  
County Clerk, Hunt County, Tex.

SALE PRICE w/ ROOFTOP COOLER + 80" BUCKET	\$112,938
EXT WARRANTY	Included
DEBRIS KIT INSTALL	\$11,973
<b>SUBTOTAL PRICE</b>	<b>\$124,911</b>
ETERRA CONTROLLER + Install	\$11,988
<b>SUBTOTAL PRICE</b>	<b>\$141,782</b>
NEW 80" Grapple Bucket	\$6,332
<b>GRAND TOTAL PRICE</b>	<b>\$143,231</b>
299 SN FD20266 w/ Standard Bucket + Grapple Bucket	-\$47,000
<b>TOTAL PRICE AFTER TRADE</b>	<b>\$96,231</b>

Quote Through Sourcewell Contract 032119 – Member 20642

**WARRANTY**

Standard Warranty: 24 Month/2000 Hour Total Machine Limited Warranty  
Extended Warranty: 60 MO/3500 HR POWERTRAIN + HYDRAULICS

**MACHINE SPECIFICATIONS**

DESCRIPTION	REF.#
299D3 CTL DCA6E	633-4126
299D3 COMPACT TRACK LOADER	597-4541
CAB PACKAGE, ULTRA	588-9140
HYDRAULICS, PERFORMANCE, (H3) - High Flow Hydraulics	512-4414
CONTROL, ISO, PROP, WT	512-4115
LIGHTS, LED	495-1671
RUBBER BELT, 2 SPD, TF IDLERS	357-0240
ROPS, ENCLOSED WITH A/C (C3)	512-3368
DISPLAY, ADVANCED, LCD, CAMERA	465-3705
FAN, COOLING, DEMAND, REVERSING	579-8782
SEAT, AIR SUSPENSION, CLOTH, HEAT	536-9738
FILM, TWO SPEED W/HIGH FLOW XPS	568-4704
STANDARD RADIO(12V), BLUETOOTH	345-6180
DEBRIS MGMT PKG, NONE (DM0) - No Debris Package	512-4089
BATTERY, EXTRA HEAVY DUTY, DISC	568-5612
REAR LIGHTS	356-6082
DOOR, CAB, POLYCARBONATE	586-1308
SEAT BELT, 2"	542-6994
PRODUCT LINK, CELLULAR PL641	573-8121
QUICK COUPLER, HYDRAULIC	512-3401
CERTIFICATION ARR, P65	563-1163
HEATER, ENGINE COOLANT, 120V	345-3556
RIDE CONTROL, NONE	512-3490

DESCRIPTION	REF.#
↑ TRACK, RUBBER, 450MM(17.71N)BLCK	389-7672
279-5377 BUCKET-GP, 80", BOCE	INCLUDED
217-6230 BUCKET-IND. GR, 80", BOCE (Industrial Grapple Bucket)	INCLUDED (Itemized Above)
451-8378 KIT, COOLER, AUXILIARY HYDR	INCLUDED
Debris Kit + Install	INCLUDED (Itemized Above)
Ettera Raptor Controller Install	INCLUDED (Itemized Above)

### STANDARD EQUIPMENT

#### OPERATOR ENVIRONMENT

FOPS, Level I	12V electric socket
Top and rear windows	Horn
Floormat	Hand (dial) & throttle electronic
Interior rear view mirror	

#### FRAMES

Lift linkage, vertical path	Support, lift arm
Chassis, one piece welded	Cast rear bumper
Machine tie down points (6)	Ventilated rear door with integrated sealing
Belly pan cleanout	

#### OTHER STANDARD EQUIPMENT

Engine enclosure - lockable	Heavy duty flat faced quick disconnects with integrated pressure release
Extended life antifreeze (-37C, -34F)	Split d-ring to route work tool hoses along side of left lift arm
Work tool coupler	Variable speed hydraulic cooling fan
Hydraulic oil level sight gauge	Per SAE J818-2007 and EN 474-3:2006 and ISO 14397-1:2007
Radiator coolant level sight gauge	
Radiator expansion bottle	
Cat ToughGuard TM hose	

#### POWERTRAIN

Cat C3.8 turbo aftercooled diesel engine	Filter, cartridge type, hydraulic
-Gross horsepower per SAE J1349	Filters, canister type, fuel and water separator
98 hp (73 kW) @ 2400 RPM	Radiator/hydraulic oil cooler (side-by-side)
-Electric fuel priming pump	Spring applied, hydraulically released, wet multi disc parking brakes
-Air inlet heater starting aid	Hydrostatic transmission
-Liquid cooled, direct injection	
Air cleaner, dual element, radial seal	
S-O-S sampling valve, hydraulic oil	

#### UNDERCARRIAGE

Dual flange front idler	Suspension - independent torsion axle(4)
Single flange rear idler	Two speed motor

#### HYDRAULICS

ISO or H pattern controls:	transmission control
Electro/hydraulic implement control	Speed sensor guarding
Electro/hydraulic hydrostatic	

#### ELECTRICAL

12 volt electrical system	-Two rear tail lights
100 ampere alternator	-Dome light
Ignition key start / stop / aux switch	Backup alarm
Lights:	Electrical outlet, beacon

-Gauge backlighting

#### OPERATOR ENVIRONMENT

Operator warning system indicators:	Gauges: DEF level, fuel level, hour meter and tachometer
-Air filter restriction	Storage compartment with netting
-Alternator output	Ergonomic contoured armrest
-Armrest raised / operator out of seat	Control interlock system, when operator leaves seat or armrest raised :
-Engine coolant temperature	-Hydraulic system disables
-Engine oil pressure	-Hydrostatic transmission disables
-Air inlet heater activation	-Parking brake engages
-Hydraulic filter restriction	ROPS Cab, open, tilt up
-Hydraulic oil temperature	
-Park brake engages	

## Tammy Himes

---

**From:** Cory Erven  
**Sent:** Monday, January 22, 2024 9:58 AM  
**To:** Tammy Himes  
**Subject:** Re: updated quoted without address

20013

---

**From:** Tammy Himes <[thimes@huntcounty.net](mailto:thimes@huntcounty.net)>  
**Sent:** Monday, January 22, 2024 7:36 AM  
**To:** Steven Harrison <[sharrison@huntcounty.net](mailto:sharrison@huntcounty.net)>  
**Cc:** Cory Erven <[cerven@huntcounty.net](mailto:cerven@huntcounty.net)>  
**Subject:** RE: updated quoted without address

Hi Steve,  
Please provide the Hunt County tag # for the 299D.

Thank you,



**Tammy Himes, CPPB**  
Purchasing Agent



2507 Lee Street, Room 104  
P O Box 1097  
Greenville, Texas 75401-1097  
☎ 903-408-4292  
📠 903-408-4242  
✉ [thimes@huntcounty.net](mailto:thimes@huntcounty.net)  
🌐 [www.huntcounty.net](http://www.huntcounty.net)

**From:** Steven Harrison <[sharrison@huntcounty.net](mailto:sharrison@huntcounty.net)>  
**Sent:** Monday, January 22, 2024 9:25 AM  
**To:** Tammy Himes <[thimes@huntcounty.net](mailto:thimes@huntcounty.net)>  
**Cc:** Cory Erven <[cerven@huntcounty.net](mailto:cerven@huntcounty.net)>; Brent Pemberton <[Brent.Pemberton@holtcat.com](mailto:Brent.Pemberton@holtcat.com)>  
**Subject:** FW: updated quoted without address

Tammy,

Here is a quote for a 299D XPS skid steer with attachments. We will be trading our current 299D in towards this new one, and paying the difference of \$96,231 out of my equipment line item. I know the trading of my current unit needs to go through court too.

If you have any questions, let me know.

Steve-

*Steven M. Harrison  
County Commissioner, Pct. 4  
Hunt County, Texas  
Phone#: 903-408-4195 / 903-886-6321  
Fax#: 903-408-4298  
FBINA 224*

[www.huntcounty.net](http://www.huntcounty.net)



**From:** Brent Pemberton <[Brent.Pemberton@holtcat.com](mailto:Brent.Pemberton@holtcat.com)>  
**Sent:** Monday, January 22, 2024 9:12 AM  
**To:** Steven Harrison <[sharrison@huntcounty.net](mailto:sharrison@huntcounty.net)>  
**Subject:** updated quoted without address

Caution! This message was sent from outside your organization.

Steve,  
Here are the quotes... I just took off address... no other changes.

Thanks,  
**Brent Pemberton**  
Holt Cat  
Government Sales Representative  
Mobile Phone: 817-219-6187

## Tammy Himes

---

**From:** Steven Harrison  
**Sent:** Monday, January 22, 2024 9:25 AM  
**To:** Tammy Himes  
**Cc:** Cory Erven; Brent Pemberton  
**Subject:** FW: updated quoted without address  
**Attachments:** Hunt County Pct4 299D XPS w\_Rooftop Cooler + debris kit + controller Quoteupdated 1-12-24.pdf

Tammy,

Here is a quote for a 299D XPS skid steer with attachments. We will be trading our current 299D in towards this new one, and paying the difference of \$96,231 out of my equipment line item. I know the trading of my current unit needs to go through court too.

If you have any questions, let me know.

Steve-

*Steven M. Harrison  
County Commissioner, Pct.4  
Hunt County, Texas  
Phone#: 903-408-4195 / 903-886-6321  
Fax#: 903-408-4298  
FBINA 224*

[www.huntcounty.net](http://www.huntcounty.net)



**From:** Brent Pemberton <Brent.Pemberton@holtcat.com>  
**Sent:** Monday, January 22, 2024 9:12 AM  
**To:** Steven Harrison <sharrison@huntcounty.net>  
**Subject:** updated quoted without address

Caution! This message was sent from outside your organization.

Steve,  
Here are the quotes... I just took off address... no other changes.

Thanks,  
**Brent Pemberton**  
Holt Cat  
Government Sales Representative  
Mobile Phone: 817-219-6187



ID

Next Asset ID

Status

- Profile
- Acquisition
- Disposal
- Depreciation
- Maintenance
- Information
- Comments
- Notes
- History

General

Description

Fund/Dept

Class

Serial Number

Tag Number

Manufacturer

Model

Note

Units on Hand

Loc. Verified

Asset Type

Type

Summary

Infrastructure

Insurance Information

Policy Name

Company

Expiration Date

Policy Value

Replacement Value

Last Note Entered

Asset Photo

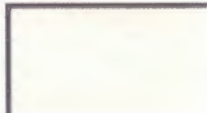

Location Information

18,623-2

FEB 13 2024

Sourcewell Quote

ASSOCIATED SUPPLY COMPANY, INC.

BECKY LANDRUM  
County Clerk, Hunt County, Tex.

Sorcewell Vendor: Associated Supply Company, Inc.

Prepared By: Phil Cobb/Josh Warner By

Phone: 972 563-2171

Mobile: 903-651-6200

Fax: \_\_\_\_\_

Email: pcobb@ascoeq.com

Date Prepared: 10/11/2023

Government Agency: HUNT COUNTY

Sourcewell Membership # 20642

Bill To: 2507 Lee ST

Ship To: \_\_\_\_\_

301 HWY 69N

PO Box 13165 - 75403

Lone Oak, TX 75453

Greenville, TX 75401

Contacts' Name: Jason White

Phone: \_\_\_\_\_

Email: jwnsw@att.net

Fax: \_\_\_\_\_

Product Description: CASE IH FARMALL 110A W/ BOOM MOWER

Sourcewell Contract: 052417-AGI

I. Price List Dated: 10/11/2023

Base Price: \$204,119.00

II: Base Bid Options (Itemized Below)

CASAE IH FARMALL 110A TRACTOR (148343)	Included
*STANDARD CAB	Included
*REAR WIPER	Included
*4 WORKLIGHTS	Included
*LESS INSTRUCTOR SEAT	Included
*DELUXE AIR SUSPENSION SEAT	Included
*16X8 POWER SHUTTLE TRANSMISSION	Included
*2 HYD. REAR REMOTES	Included
*13.6R28 FRONT TIRES -	Included
*18.4R34 REAR TIRES-	Included

SUB-TOTAL: \$ -

*HD FRONT MFD AXLE	Included
*HD FLANGE REAR AXLE	Included
*AND ALL OTHER STANDARD EQUIPMENT	Included
ALAMO INDUSTRIAL	Included
*22' SAMURI BOOM MOWER	Included
*60" SEVERE DUTY ROTARY CUTTER	Included
*BLADE PAN/ SWIVEL	Included
*MOUNTING KIT	Included
*AND ALL OTHER STANDARD EQUIPMENT	Included

SUB-TOTAL: \$ -

Options List Price Total: \$ -

\$ 204,119.00

III. SUB-TOTAL OF I & II

IV. Sourcewell Discount: 15.00% \$ 30,617.85

Sourcewell CONTRACT PRICE: \$ 173,501.15

V: NON-BASE OPTIONS

Non-Base Options (%) = 0

SHIPPING & HANDLING \$ 1,992.85

\$ -

PDI / SET UP \$ 900.00

\$ -

DELIVERY \$ 250.00

\$ -

SUB-TOTAL: \$ 3,142.85

SUB-TOTAL: \$ -

VI: UNPUBLISHED OPTIONS ADDED TO CONTRACT PRICE (SUBTOTAL OF COL1 & COL 2)

\$ 3,142.85

VII: TOTAL IV + VI

\$ 176,644.00

VIII: QUANTITY ORDERED UNITS: 1

\$ 176,644.00

IX: TRADE-IN OR OTHER CREDIT(S): \$ 8,000.00 FALL STOCK EOP

\$ 8,000.00

TOTAL: \$ 168,644.00

IX: WARRANTY:

(800) 687-0008  
www.AscoEq.com



**REMIT TO**  
**ASCO EQUIPMENT**  
**P.O. BOX 3888**  
**LUBBOCK, TX 79452**

<b>ORDER NO</b> ESA026982V1	<b>DATE</b> 02-05-2024
<b>PAYMENT TERMS</b> Cash on Delivery	

ASCO EQUIPMENT  
401 FARM-TO-MARKET 148  
TERRELL TX 75160  
(972) 563-2171

<b>CUSTOMER NO</b> BP0084721
<b>CUSTOMER PO</b> Cash on Delivery

**EQUIPMENT SALES AGREEMENT**

**INVOICE TO:**

HUNT COUNTY #3  
301 HWY 69N  
LONE OAK TX 75453  
903 461-9783

**SHIP TO:**

HUNT COUNTY #3  
301 HWY 69N  
LONE OAK TX 75453  
903 461-9783

**SALESMAN** : Joshua Warner

**DELIVERY TERMS** :

UNIT	QTY	UNIT PRICE	TOTAL
EQ0141324 Case IH F110A Tractor W/ Samurai 22' Boom Mow Case MODEL:F110 S/N:CT002204M	1	168,644.00	168,644.00
<b>SUB TOTAL</b>			<b>168,644.00</b>

TOTAL PURCHASE	168,644.00
SALES TAX	0.00
<b>TOTAL AMOUNT (USD)</b>	<b>168,644.00</b>

ASCO EQUIPMENT

CUSTOMER ACCEPTANCE



## TERMS, LIENS, AND CONDITIONS

Customer agrees to the following terms and conditions in regard to the purchase of the equipment, parts or repairs described on the front of this agreement (these terms and conditions include the information on the front of this agreement and the terms and conditions stated within the Customer's credit application and rental agreement, if any, all of which are part of this agreement):

**Inspections; Acceptance of Parts and/ or Equipment.** Customer represents and acknowledges that it has inspected the goods, services and equipment purchased by Customer from Associated Supply Company, Inc. ("ASCO"), finds the same to be in satisfactory condition, properly operating, and fit for the use or purpose intended by Customer. Customer acknowledges that the equipment or parts purchased have been selected solely by Customer for the purpose such equipment or parts are to be used and without reliance on ASCO or its employees, and that ASCO (i) has not selected the equipment or parts purchased, and (ii) is not responsible for the suitability of the equipment for the use Customer intends. **Customer agrees that except as expressly set forth in this agreement, ASCO is not liable for and makes no warranties, either express, implied, or by operation of law, as to any matter whatsoever including, without limitation, the condition of the equipment or parts, its merchantability, or its fitness for any particular purpose, and Customer releases ASCO to the fullest extent allowed by law from any warranties, express, implied or arising by operation of law. There are no warranties which extend beyond the description of the equipment or parts on the front of this agreement.**

**Lien and Security Interest Related to Repair Work.** Customer hereby authorizes all repair work to be done along with materials therefore and other repairs and materials incidental thereto. ASCO's employees may operate the above vehicles for purposes of testing, inspection or delivery at Customer's risk. An express possessory lien under Chapter 70, Subchapter A of the *Texas Property Code*, and a Security Interest under Title 1, Chapter 9 of the *Texas Business and Commerce Code (Uniform Commercial Code – Secured Transactions)* is granted to ASCO upon the machines, equipment and vehicles being repaired to secure all charges for labor, materials, and related expenses. Possession of the machines, equipment and vehicles may remain with ASCO until all charges are paid or arrangements satisfactory to ASCO are made. ASCO will not be held responsible for loss or damage to machines, equipment, or vehicles or articles left therein in case of fire, theft, accident or any other cause beyond ASCO'S control. Repairs are warranted for 90 days after the date of the repair; however, no warranty will apply if the invoice for such repairs is unpaid.

**NOTICE OF RIGHT TO TAKE POSSESSION OF EQUIPMENT FOR UNPAID REPAIRS.** *As indicated by its signature on the front of this agreement, Customer agrees that the equipment repaired by ASCO is subject to repossession in accordance with Section 9.609 of the Texas Business and Commerce Code if payment of a check, money order, or a credit card transaction is stopped, is dishonored because of insufficient funds, no funds on deposit, or because the drawer or maker of the check, money order or the credit card holder has no account or the account has been closed.*

**Security Interest.** Title to the goods, services and equipment will remain with ASCO until the total purchase price of goods, services and equipment has been paid in full. Customer grants to ASCO an express security interest under Title 1, Chapter 9 of the *Texas Business and Commerce Code* in the goods, services, and equipment to secure all charges therefore. In event of default in payment for the goods, services and equipment described herein, no further charges or purchases will be allowed. Purchaser further agrees to pay all costs of collection or enforcement hereof, including reasonable attorney's fees, for charges not paid that are more than 30 days past due. **Exclusive jurisdiction and venue for any litigation between Customer and ASCO is in any district court or county court of law of Lubbock County, Texas. CUSTOMER HEREBY UNCONDITIONALLY WAIVES ITS RIGHTS TO A JURY TRIAL.**

### **Parts Policies:**

- Back ordered items will be shipped as soon as available.
- Electrical parts are non-returnable.
- Special order parts and parts "made as ordered" are non-refundable.
- Cores must be returned for credit within 10 days of purchase.
- Returned parts must be accompanied by a packing list or invoice and are subject to a 15% restocking charge.
- Claims for shortages or damages must be received within 5 days of sale.

**Limitation of Purchaser's Remedies.** The Customer's remedies, in the event of any claim made by the Customer against ASCO with respect to the goods, services and equipment sold here, shall be limited to return of such goods and equipment and repayment of the purchase price therefore or to repair and replace nonconforming goods, services and equipment. No consequential damages are permitted against ASCO in connection with the sale or the use of the goods, services and equipment sold here.

**Indemnification.** *To the fullest extent permitted by law, Customer agrees to indemnify and hold harmless ASCO from and against any and all liability, suits, claims, demands and actions, and costs and expenses, including reasonable attorney's fees, loss of profit, business interruption or other special or consequential damages, damages relating to property damage, bodily injury, or damages relating to wrongful death, claimed against ASCO, and any of ASCO's officers, directors, agents, or employees, arising out of or related to the services, parts, equipment, supplies, goods and services furnished here, whether caused in whole or in part by the negligence of ASCO; however, this paragraph is not intended to indemnify ASCO for the replacement costs thereof as set forth above or parts, services or equipment supplied by ASCO which has been expressly warranted in writing.*

**Service Charge.** All accounts past due 30 days will be charged a service charge at the periodic rate of 1 ½% per month, which is an annual percentage rate of 18%.

**Like Kind Exchange.** Notice is hereby given that ASCO may assign its rights under this agreement to ASCO Exchange, LLC (or other entity) to sell the rental equipment described herein and, if applicable, to purchase trade-in property described herein.

10-614-1800-2260

18,623-3

FILED FOR RECORD  
at 2:00 o'clock P M

FEB 13 2024

BECKY LANDRUM  
County Clerk, Hunt County, Tex.

By 



**Strategic Service Solutions**

COMMERCIAL HVAC/R EXPERTS

Strategic Service Solutions

Proposal For:

**PREVENTIVE MAINTENANCE AGREEMENT**

\*\*\*\* with additional condensate pump services \*\*\*\*

Prepared By:

**Brian Sullins**

Account Representative

For:

**Laizza Harkey**

**Hunt County Courthouse**



**HUNT COUNTY**  
• TEXAS •

# PREVENTIVE MAINTENANCE AGREEMENT

Strategic Service Solutions  
1945 Wind Hill Rd  
Rockwall, TX 75087  
(All bills payable to the above address)

Date: 12/31/23  
Quote #: 0  
Account Representative: Brian Sullins

**The Agreement made between:**

**Strategic Service Solutions**

and the Customer listed below.

Hunt County Courthouse  
2507 Lee St  
Greenville, TX 75401

Service to be performed at:

Hunt County Courthouse  
2507 Lee St  
Greenville, TX 75401

Strategic Service Solutions is providing a system of maintenance for the equipment type contained within the schedules, terms and conditions on the pages attached and listed below.

- Schedule "A": Describes the level of service being provided by the Agreement.
- Schedule "B": Describes the limit of liability and the terms and conditions.
- Schedule "C": Describes the equipment and services to be covered on equipment.
- Schedule "D": Describes the scheduled tasks to be performed for equipment listed in "Schedule C".
- Schedule "E": Describes additional or special services to be performed. (If applicable.)

The yearly Service Fees for this Agreement are listed below.

Year 1	Service Fee	<u>\$9,114.59</u>	plus Sales Tax	<u>\$0.00</u>	Total	<u>\$9,114.59</u>
--------	-------------	-------------------	----------------	---------------	-------	-------------------

Yearly Service Fees to be paid in equal installments as listed below.

Year 1	4	Installments of	<u>\$2,278.65</u>	plus Sales Tax	<u>\$0.00</u>	Total	<u>\$2,278.65</u>
--------	---	-----------------	-------------------	----------------	---------------	-------	-------------------

The first payment is due on the day coverage begins February 1, 2024  
Coverage shall continue for 1 year(s).

The schedules attached to the service Agreement constitute the entire Agreement between the Strategic Service Solutions and the Customer. The service Agreement remains the property of the Contractor and is provided for the Customer's use only. This service Agreement is subject to management approval by Strategic Service Solutions. No waiver, change or modification of any terms or conditions shall be binding on Strategic Service Solutions unless made in writing and signed by authorized management of Strategic Service Solutions.

Strategic Service Solutions Representative  
By: Brian J Sullins  
Printed Name: Brian J Sullins  
Title: Owner

Authorized Customer Signature  
By: Chris Kilmer  
Printed Name: Chris Kilmer  
Title: Facilities Director

# SCHEDULE "A"

## Level of Service

### Performance Review

A performance review is held with the Customer on an annual basis. Discussions include quality of work, and improvement suggestions. Items needing attention are addressed in a timely fashion.

### Reports

Each completed service call is documented by an Strategic Service Solutions service report. This report is provided to the customer as evidence of the completed service showing each performed task.

### Scheduled Tasks

The service program is designed to provide continuing maintenance on the equipment listed in schedule "D" of the Agreement. The tasks planned and scheduled are designed to provide for the long term care of the customer's equipment.

Each service visit will be scheduled and prepared by the contractors dispatch system.

The Strategic Service Solutions schedule includes specific tasks for each piece of equipment required to maintain the systems at peak efficiency.

### Maintenance

The run-time, use and application of the piece of equipment determine the equipment service frequency. This information, along with manufacturer's recommendations and our experience assures the customer's equipment receives the most cost-effective maintenance in the industry.

### Emergency Service

Strategic Service Solutions is on call and can provide all labor, travel and expenses, parts and materials seven days a week, twenty-four hours a day. Emergency Service is invoiced separately from this Agreement.

# SCHEDULE "B"

## Terms and Conditions

1. **PERFORMANCE.** The materials and methods used will comply with federal, state and local laws. All material is guaranteed to be as specified. All work to be completed in a workmanlike manner according to standard practices. Failure to perform as described may be considered as grounds for review and arbitration of the required scope of work and/or termination of this Agreement. Duty to perform is subject to credit approval. This Agreement may not be assigned by Customer without the prior written consent of Strategic Service Solutions. The obligations of Strategic Service Solutions shall terminate at the option of Strategic Service Solutions and without notice to Customer in the event of any condition or cause beyond the control of Strategic Service Solutions which affects the performance of the obligations of Strategic Service Solutions under this Agreement, including, but not limited to, the misuse of the equipment, negligence of Customer or others, strikes, accident, fire, flood, wind, acts of God, governmental action, power outages, or loss of use of material and service sources.
2. **COOPERATION.** Your cooperation is important to ensure the most effective results from Strategic Service Solutions service. The contractor must be admitted into all areas of the premises for the purpose of completing services. If available, the Owner will provide any site drawings or detail to assist the Contractor. Strategic Service Solutions will inform you in writing of reasonable corrections which must be made in a location in order to complete work; however, if you fail to correct the identified conditions, you may be charged for additional services. Customer agrees to operate and maintain systems in accordance with Strategic Service Solutions instructions, maintain communication means (i.e. phone lines, internet connection, radio antenna, etc) in proper working order, maintain city alarm permits if applicable, and allow only Strategic Service Solutions technicians to complete the work.
3. **TERM, RENEWAL, and CANCELLATION.** If Strategic Service Solutions fails to comply with the specifications, they shall be given (30) days notice to correct the problem. If, at the expiration of such thirty days, the unsatisfactory conditions have not been corrected, you reserve the right to cancel the contract. This agreement may be adjusted or terminated if service requirements or equipment have been modified. This Agreement shall be considered in effect for the initial period of twelve (12) months from the date of the first service, and unless cancelled by either party, will automatically continue on a monthly basis until cancelled by either party upon thirty (30) days notice. Strategic Service Solutions shall be due any pro-rated fees as of the cancellation date.
4. **WARRANTIES.** Strategic Service Solutions warrants that: (1) Strategic Service Solutions manufactured material is free from defect in material and manufacture for a period of twelve months from date of start-up or replacement. Strategic Service Solutions's obligation under this warranty is limited to repairing or replacing the defective part at its option; (2) Labor is warranted (to have been properly performed) for a period of 90 days from completion. Strategic Service Solutions under this warranty is limited to correcting any improperly performed labor; (3) Non-Strategic Service Solutions equipment and/or parts are not warranted by Strategic Service Solutions. Warranties for such equipment and parts are those extended to Strategic Service Solutions by the respective manufacturer. There are absolutely no other warranties extended, including any implied warranties of FITNESS FOR PARTICULAR PURPOSE OR MERCHANTABILITY.
5. **INDEMNITY AND LIABILITY.** Strategic Service Solutions AND CUSTOMER SHALL INDEMNIFY, DEFEND AND HOLD EACH OTHER HARMLESS FROM ANY AND ALL CLAIMS, ACTIONS, COSTS, EXPENSES, DAMAGES, AND LIABILITIES, INCLUDING ATTORNEYS' FEES, RESULTING FROM DEATH OR BODILY INJURY OR DAMAGE TO REAL OR PERSONAL PROPERTY, TO THE EXTENT CAUSED BY THE NEGLIGENCE OR MISCONDUCT OF THEIR RESPECTIVE EMPLOYEES OR THEIR AUTHORIZED AGENTS IN CONNECTION WITH THEIR ACTIVITIES WITHIN THE SCOPE OF THIS AGREEMENT. HOWEVER, NEITHER PARTY SHALL INDEMNIFY THE OTHER AGAINST CLAIMS, DAMAGES, EXPENSES, OR LIABILITIES TO THE EXTENT ATTRIBUTABLE TO THE NEGLIGENCE OR MISCONDUCT OF THE OTHER PARTY. IF THE PARTIES ARE BOTH AT FAULT, THE OBLIGATION TO INDEMNIFY SHALL BE PROPORTIONAL TO THEIR RELATIVE FAULT. THE DUTY TO INDEMNIFY WILL CONTINUE IN FULL FORCE AND EFFECT, NOTWITHSTANDING THE EXPIRATION OR EARLY TERMINATION HEREOF, WITH RESPECT TO ANY CLAIMS BASED ON FACTS OR CONDITIONS THAT OCCURRED PRIOR TO THE EXPIRATION OR TERMINATION. NOTWITHSTANDING ANY CONTRARY PROVISION, NEITHER PARTY SHALL BE LIABLE FOR INCIDENTAL OR CONSEQUENTIAL DAMAGES OF ANY NATURE WHETHER CLAIMED UNDER CONTRACT, WARRANTY, NEGLIGENCE, STRICT LIABILITY OR ANY OTHER LEGAL THEORY.
6. **LEGAL COMPLIANCE.** Strategic Service Solutions will comply with applicable federal, state and local laws and obtain requisite temporary licenses and permits for it work hereunder. Customer will obtain at its cost any requisite permanent licenses and permits.
7. **ATTORNEY FEES.** Customer will pay for reasonable attorney fees incurred by Strategic Service Solutions in enforcing collection of amounts due.
8. **INSURANCE.** Strategic Service Solutions agrees to carry insurance in the following minimum amounts:

a. Commercial General Liability	\$1,000,000 per occurrence
b. Automobile Liability	\$1,000,000 CSL
c. Workers Compensation	Statutory Limits
9. **ASBESTOS AND HAZARDOUS MATERIALS.** Strategic Service Solutions Work and other services in connection with this Agreement expressly excludes any identification, abatement, cleanup, control, disposal, removal or other work connected with asbestos, poly chlorinated biphenyl ("PCB"), or other hazardous materials (hereinafter, collectively, "Hazardous Materials"). Customer warrants and represents that, except as set forth in writing, there are no Hazardous Materials on the Premises that will in any way affect Strategic Service Solutions Work and Customer has disclosed to Strategic Service Solutions the existence and location of any Hazardous Materials. If Strategic Service Solutions identifies any Hazardous Materials, Strategic Service Solutions may immediately stop work in the affected area and shall notify Customer. Customer will be responsible for taking any and all action necessary to correct the condition in accordance with all applicable laws and regulations. Customer shall be exclusively responsible for any claims, including the payment thereof, arising out of or relating to any Hazardous Materials on or about the Premises, not brought onto the Premises by Strategic Service Solutions. Strategic Service Solutions shall be required to resume performance of the Work in the affected area only in the absence of Hazardous Materials or when the affected area has been rendered harmless. In no event shall Strategic Service Solutions be obligated to transport or handle the Hazardous Material, to provide any notices to any governmental agency,
10. **EXCLUSIONS**
  - a. Pre-existing conditions that are identified during the initial inspection, performed by Strategic Service Solutions, of covered equipment.
  - b. Repairs or services resulting from, but not limited to, acts of God or war, severe weather, civil disorders, natural disasters, fire, terrorism, damage caused by equipment not covered by this agreement or damage caused by someone other than Strategic Service Solutions personnel.
  - c. Refrigerant.
  - d. Repair or replacement of non-maintainable parts of the system(s) such as, but not limited to, coils, heat exchangers, duct work, piping, shell and tube, unit cabinets, boiler refractory material, insulating material, electrical wiring, hydronic and pneumatic piping, structural supports and other non-moving parts, are not included in this Agreement.
11. **Strategic Service Solutions OBLIGATION**
  - a. Strategic Service Solutions agrees to perform all work professionally and to provide only materials of good quality.
  - b. All maintenance tasks will be performed during the Strategic Service Solutions normal working hours.
12. **CUSTOMER OBLIGATION**
  - a. The customer agrees to inform the Strategic Service Solutions immediately of problems found in the operation of the equipment.
  - b. The customer agrees to pay and be responsible for any additional gross amount of any present or future sales, use, excise, value-added, or other similar tax, however designated, applicable to the price, sale or delivery of any products, services or the work furnished hereunder or for their use by Strategic Service Solutions on behalf of the customer whether such tax shall be local, state, or federal in nature. This will include but not be limited to the recovery, recycling, reclamation, handling and disposal of all refrigerants, and the additional costs incurred for refrigerant tax and/or increased costs due to shortages.
  - c. Customer agrees to operate the subject equipment in accordance with Strategic Service Solutions instructions.
  - d. Customer agrees to permit only Strategic Service Solutions personnel to work on subject equipment.
  - e. The customer provides reasonable access to all areas and equipment, and allows Strategic Service Solutions to stop and start equipment as necessary to fulfill the terms of the Agreement.
13. **Acceptance.** This instrument embodies the entire agreement between Customer and Strategic Service Solutions, and any modifications or amendments must be in writing and signed by both parties. This proposal may be withdrawn by Strategic Service Solutions if not accepted within 30 days of date of proposal.

Corporate Office:  
1945 Wind Hill Rd. Rockwall, TX 75087  
Phone: 214-897-3131

TACLA120026C

Regulated by The Texas Department of Licensing and Regulations. PO Box 12157, Austin, Texas /8711. 1-800-803-9202, 512-463-6599

Texas State Board of Plumbing Examiners. P.O. Box 4200, Austin, TX 78765. Phone 512-936-5200 Fax 512-450-0637 800-845-6584 www.tsbpe.state.tx.us

REV. 011716



## SCHEDULE "D"

## VARIABLE REFRIGERANT VOLUME SYSTEM

### INSPECTION SCOPE

#### Annual (1per Year)

- Check in with facility manager on arrival to discuss any operating issues or deficiencies
- Document alarm history
- Inspect outdoor unit control section wiring/components for signs of overheating and discoloration
- Check outdoor unit control section electrical connections for tightness
- Clean outdoor unit control section and secure loose wiring
- Inspect outdoor fan – motor, blades, and bearings
- Inspect compressor terminal box connections
- Inspect outdoor unit refrigerant circuit for signs of oil/refrigerant leaks
- Check compressors and outdoor fan motors – amperage and voltage
- Check for abnormal compressor and outdoor fan noise/vibration
- Check operation of crankcase heaters
- *Clean outdoor coil*
- Inspect indoor unit control section wiring/components for signs of overheating and discoloration
- Check indoor unit control section electrical connections for tightness
- Clean indoor unit control section and secure loose wiring
- Check indoor unit fan wheel for dust/dirt accumulation
- Check indoor unit for abnormal noise/vibration
- *Clean indoor unit filters*
- *Clean indoor unit condensate pump*
- Wipe down indoor unit case
- Log system with Daikin Service Checker software
- Check refrigerant target pressures and temperatures via software
- Check outdoor unit sensors via software (discharge temp, outdoor air temp, gas temp, liquid temp)
- Check indoor unit sensors via software (liquid temp, gas temp, superheat/subcooling, EEV%)
- Discuss deficiencies and recommendations with facility manager

#### Run Inspection (3per Year)

- Check in with facility manager on arrival to discuss any operating issues or deficiencies
- Document alarm history
- Inspect outdoor unit control section wiring/components for signs of overheating and discoloration
- Inspect outdoor unit refrigerant circuit for signs of oil/refrigerant leaks
- Check compressors and outdoor fan motors – amperage and voltage
- Check for abnormal compressor and outdoor fan noise/vibration
- Check operation of crankcase heaters
- Check indoor unit for abnormal noise/vibration
- *Clean indoor unit filters*
- Wipe down indoor unit case
- Log system from outdoor unit with Daikin Service Checker software
- Check refrigerant target pressures and temperatures via software
- Check outdoor unit sensors via software (discharge temp, outdoor air temp, gas temp, liquid temp)
- Check indoor unit sensors via software (liquid temp, gas temp, superheat/subcooling, EEV%)
- Discuss deficiencies and recommendations with facility manager



## SCHEDULE "E"

### Clarifications:

- All work listed in this Agreement to be performed during normal business hours unless specified otherwise in this proposal.

FEB 13 2024

BECKY LANDRUM  
County Clerk, Hunt County, Tex.

By

**HUNT COUNTY BID AWARD**  
**RFP #243-24, Prefabricated Concrete Communication Equipment Shelters**  
February 13, 2024

	VENDOR
	CellSite Solutions, LLC.
<b>Shelter, Caddo Mills Site</b>	
a. 11'X16'-side door configuration only	\$76,950.00
b. Freight to 75428	\$13,380.00
<b>Shelter, Celeste Site</b>	
a. 11'X16'	\$76,960.00
b. Freight to 75423	\$13,385.00
<b>Shelter, Commerce Site</b>	
a. 10'X16' only	\$75,300.00
b. Freight to 75428	\$12,502.00
<b>Shelter, Greenville Site</b>	
a. 11'X16'	\$76,950.00
b. Freight to 75401	\$13,385.00
<b>Shelter, Quinlan Site</b>	
a. 11'X16'	\$76,950.00
b. Freight to 75474	\$13,380.00
<b>Discount: Less ach or check (non Ecard payment)</b>	-\$20,210.94
<b>TOTAL 5 SHELTERS INCLUDING 5 FREIGHT CHARGES</b>	<b>\$428,921.06</b>
The Hunt County Purchasing Department recommends award of this bid to CellSite Solutions, LLC.	
the only responsive bidder	

## Tammy Himes

---

**From:** Laizza Harkey  
**Sent:** Tuesday, February 6, 2024 5:43 AM  
**To:** Tammy Himes  
**Subject:** Fwd: CellSite Solutions, LLC: Quote #QUO-9091

There is the payments I do believe it will it might change a little.

Get [Outlook for iOS](#)

---

**From:** Lora Vestal <lora.vestal@yahoo.com>  
**Sent:** Monday, February 5, 2024 3:20 PM  
**To:** Chris Kilmer <ckilmer@huntcounty.net>; Laizza Harkey <lharkey@huntcounty.net>  
**Subject:** Fw: CellSite Solutions, LLC: Quote #QUO-9091

Caution! This message was sent from outside your organization.

[Sent from Yahoo Mail for iPhone](#)

Begin forwarded message:

On Monday, February 5, 2024, 3:19 PM, Lora Vestal <lora.vestal@yahoo.com> wrote:

Thank you. And thank you for the weights.

[Sent from Yahoo Mail for iPhone](#)

On Monday, February 5, 2024, 2:46 PM, Andrew Gallagher <andrewg@cellsitesolutions.com> wrote:

LB – With the attached quote (tax has been removed), the billing milestones would be as follows:

50% billed upon execution - \$214,460.53 *TO BE PAID FOLLOWING COURT ON 2.13.24*  
30% billed upon shelter make ready - \$128,676.32  
10% upon delivery - \$42,892.10  
10% upon final inspection/approval - \$42,892.11



**Andrew Gallagher**  
Director Of Sales  
Mobile: 319-210-2974  
Desk: 319-531-7843  
[andrewg@cellsitesolutions.com](mailto:andrewg@cellsitesolutions.com)  
4150 C Street SW



Cedar Rapids, IA 52404

[cellsitesolutions.com](http://cellsitesolutions.com)



[cellsitegolf.com](http://cellsitegolf.com)



CellSite Solutions, LLC  
 CellSite Solutions, LLC  
 4150 C Street SW  
 Cedar Rapids IA 52404  
 United States

**Quote**  
 #QUO-9091  
 2/5/2024

**CUSTOMER**  
 Hunt County Texas  
 Greenville TX 75401  
 United States

**LOCATION**  
 Hunt County Texas  
 Greenville TX 75401  
 United States

**TOTAL**  
**\$428,921.06**  
 Expires: 2/16/2024

**Expires** 2/16/2024      **Project**      **Sales Rep** Andrew Gallagher      **Shipping Method**

**Project Name**  
 (5) Shelters - L3 Harris - Hunt County TX

Qty	Item	Rate	Amount
4	<b>Shelter *TBD*</b> Previously deployed concrete shelter package, includes all options below. Sizes ranging from 10'x12 to 10'x16	\$76,950.00	\$307,800.00
1	<b>Shelter *TBD*</b> Previously deployed 10'x16' shelter, includes all options below.	\$75,300.00	\$75,300.00
1	<b>Refurbish Services*</b> Humidistats and electrostatic fans per RFP spec.	\$0.00	\$0.00
10	<b>3 Ton BARD non-econ*</b> 3 TON Bard Non-Econ units with lead lag controller and manufacturer warranty	\$0.00	\$0.00
5	<b>Full Exterior Refurb</b> Full Exterior Refurb. Includes: - Concrete Sealant / Paint - Trim Paint - Awning Paint - Door Paint - Caulking of all Seams	\$0.00	\$0.00
5	<b>Polyvinyl Roof</b> Polyvinyl Roof Solution. Includes 2 year workmanship, 10 year materials warranty. Includes applicable travel deployment cost.	\$0.00	\$0.00
5	<b>Floor Overlay</b> Supply & Install New Industrial Type Electrostatically Grounded Floor Overlay	\$0.00	\$0.00
5	<b>Lifting Brackets</b> Lifting Brackets  **Customer will receive a refund for the Lifting Brackets if they are returned to Cellsite Solutions within 30 days of Shelter Delivery. Return shipping of the brackets is the responsibility of the Buyer.	\$0.00	\$0.00
5	<b>Crane Upload</b> Crane Upload	\$0.00	\$0.00



QUO-9091



CellSite Solutions, LLC  
 CellSite Solutions, LLC  
 4150 C Street SW  
 Cedar Rapids IA 52404  
 United States

**Quote**  
 #QUO-9091  
 2/5/2024

Qty	Item	Rate	Amount
5	<b>Tie Down Plates</b> Tie Down Plates installed by others	\$0.00	\$0.00
2	<b>Shipping - Common Carrier</b> Shipping of Shelter to within 25 miles of	\$13,380.00	\$26,760.00
<p>**Due to the recent changes in the Shipping Industry, Cellsite Solutions cannot guarantee the shipping rates until 7 days prior to delivery. This number is budgetary.</p> <p>**This quote assumes normal access to the Site. If the site is deemed difficult, then additional charges may apply.</p> <p>**In order to best serve our customers, an accurate ship date is required. If Customer provides a ship date that is used to schedule &amp; complete any refurbish services, and the Customer does not comply with said ship date, Customer agrees to allow Cellsite Solutions to issue an invoice for the remaining balance due, less shipping &amp; craning. Customer understands that this invoice must be paid in full before a new ship date can be agreed-upon. The final invoice for the shipping &amp; craning will be issued upon shelter delivery.</p>			
2	<b>Shipping - Common Carrier</b> Shipping of Shelter to within 25 miles of Texas zip codes 75423, 75134, 75474, 75428, and 75401	\$13,385.00	\$26,770.00
<p>**Due to the recent changes in the Shipping Industry, Cellsite Solutions cannot guarantee the shipping rates until 7 days prior to delivery. This number is budgetary.</p> <p>**This quote assumes normal access to the Site. If the site is deemed difficult, then additional charges may apply.</p> <p>**In order to best serve our customers, an accurate ship date is required. If Customer provides a ship date that is used to schedule &amp; complete any refurbish services, and the Customer does not comply with said ship date, Customer agrees to allow Cellsite Solutions to issue an invoice for the remaining balance due, less shipping &amp; craning. Customer understands that this invoice must be paid in full before a new ship date can be agreed-upon. The final invoice for the shipping &amp; craning will be issued upon shelter delivery.</p>			
1	<b>Shipping - Common Carrier</b> Shipping of Shelter to within 25 miles of Zip 75428	\$12,502.00	\$12,502.00
<p>**Due to the recent changes in the Shipping Industry, Cellsite Solutions cannot guarantee the shipping rates until 7 days prior to delivery. This number is budgetary.</p> <p>**This quote assumes normal access to the Site. If the site is deemed difficult, then additional charges may apply.</p> <p>**In order to best serve our customers, an accurate ship date is required. If Customer provides a ship date that is used to schedule &amp; complete any refurbish services, and the Customer does not comply with said ship date, Customer agrees to allow Cellsite Solutions to issue an invoice for the remaining balance due, less shipping &amp; craning. Customer understands that this invoice must be paid in full before a new ship date can be agreed-upon. The final invoice for the shipping &amp; craning will be issued upon shelter delivery.</p>			



QUO-9091



CellSite Solutions, LLC  
 CellSite Solutions, LLC  
 4150 C Street SW  
 Cedar Rapids IA 52404  
 United States

**Quote**  
 #QUO-9091  
 2/5/2024

Qty	Item	Rate	Amount
1	<b>Discount</b> Less ACH or check (non Ecard payment) – Subtract \$20,210.94	\$-20,210.94	\$-20,210.94
		<b>Subtotal</b>	\$428,921.06
		<b>Tax (%)</b>	\$0.00
		<b>Total</b>	\$428,921.06

\*Please note all formal quotes are good for 7 business days from the date on the quote. Shipping price is valid only for 7 days from date of quote and must be re-quoted within 7 days of item delivery due to the current shipping climate.  
 \*All quotes are subject to equipment availability.  
 \*HVAC Testing is intended only to verify the current condition of existing unit(s). Buyer understands that the Seller makes no warranty claims and that the Seller suggests having a licensed HVAC/Mechanical contractor on site at the time of installation.  
 \*Unless otherwise agreed upon in writing, payment terms are 50/50: 50% due upon sales agreement execution or Purchase Order issuance; remaining 50% including shelter price due upon completion of Refurb Services or HVAC installation; remaining 50% of civil work due upon completion of Civil Services; or due upon delivery; or 60 days from the date of purchase, whichever comes first. Interest will be charged at a rate of 1.5% per month on any outstanding past due balance.  
 \*Purchase price is subject to tax unless proper tax exempt documents are provided to CellSite Solutions, LLC.  
 \*Equipment Storage: includes but is not limited to Shelters, Cabinets, HVACs, Generators, and Inside Plant Equipment provided at cost to the Purchaser until the set delivery date. CellSite Solutions' Project Management establishes the delivery date according to the requirements. CellSite Solutions will send an email notification of project status and initiate a verbal notice via phone or video conference to the Purchaser 30 days before the set delivery date. CellSite Solutions will send a second communication to the Purchaser 15 days before the set delivery date with updated project status and final confirmation of the delivery date. If the Purchaser does not accept the delivery date identified within the 15-day final confirmation email, CellSite Solutions will charge the Purchaser a \$20.00 per day and per item(s) storage fee for any item(s). In addition, a minimum fee of \$950 will be included in the first month billing to cover costs associated with the upload, offload, or transportation of the Purchaser's equipment to clear the CellSite production facility space.  
 \*Unless otherwise noted, offload is not included in the price and is the responsibility of the Buyer.  
 \*Unless otherwise noted, Buyer is responsible for any related building/electrical/mechanical/zoning permitting.  
 \*For all shipping and crane offload services performed by CellSite Solutions: any cancellation of these services by the Buyer without a minimum 5-DAY NOTICE will incur a fee of 18% of the quoted shipping & offload prices.

**SALE AGREEMENT**

THIS SALE AGREEMENT (this "Agreement") is made and entered into as of the date signed below by and between Cellsite Solutions, LLC, an Iowa limited liability company whose mailing address is 4150 C Street SW, Cedar Rapids, IA 52404 ("Seller"), and ("Buyer") as listed in above quote as "CUSTOMER".

**WITNESSETH:**

WHEREAS, Seller is the owner of the property described above (the "Materials") that may be refurbished for Buyer (the "Refurb Services"), that may require certain civil services to the site (the "Civil Services") and may be delivered to Buyer (the "Project"); and

WHEREAS, Seller desires to sell and Buyer desires to purchase the Project subject to the terms and conditions of this Agreement.

NOW, THEREFORE, in consideration of the foregoing and the mutual promises and other terms and conditions hereinafter set forth, and intending to be legally bound hereby, the parties agree as follows:

**SECTION 1. TERMS OF SALE**

1.1 Seller hereby sells, transfers and assigns the Materials to Buyer with warranty of title, free and clear of all liens or encumbrances, and performs any agreed upon Refurb Services and/or Civil Services for the total pricing as listed in above Quote, and unless otherwise stated above:

1.1.1 50% of quoted price upon Execution of this Agreement, plus any applicable tax;

1.1.2 remaining 50% of Refurb/HVAC Services including shelter price within ten (10) days after written notice (which may include email) from Seller that any Refurb Services are complete plus applicable sales tax; and





CellSite Solutions, LLC  
CellSite Solutions, LLC  
4150 C Street SW  
Cedar Rapids IA 52404  
United States

Quote  
#QUO-9091  
2/5/2024

1.1.3 remaining 50% of Civil Services within ten (10) days after written notice (which may include email) from Seller that any Civil Services are complete plus applicable sales tax; and

1.1.4 any remaining balance plus applicable sales tax upon delivery of the Project or 60 days from the date of this Agreement, whichever comes first.

The "Purchase Price" includes crane upload of the Project. Unless otherwise stated in above Quote, Crane offload of the Project and shipping is not included and is the responsibility of the Buyer. Applicable sales tax is the responsibility of the Buyer. Equipment Storage: includes but is not limited to Shelters, Cabinets, HVACs, Generators, and Inside Plant Equipment provided at cost to the Purchaser until the set delivery date. CellSite Solutions' Project Management establishes the delivery date according to the requirements. CellSite Solutions will send an email notification of project status and initiate a verbal notice via phone or video conference to the Purchaser 30 days before the set delivery date. CellSite Solutions will send a second communication to the Purchaser 15 days before the set delivery date with updated project status and final confirmation of the delivery date. If the Purchaser does not accept the delivery date identified within the 15-day final confirmation email, CellSite Solutions will charge the Purchaser a \$20.00 per day and per item(s) storage fee for any item(s). In addition, a minimum fee of \$950 will be included in the first month billing to cover costs associated with the upload, offload, or transportation of the Purchaser's equipment to clear the CellSite production facility space.

1.2 Buyer acknowledges that the Seller did not manufacture the Materials and therefore cannot provide a warranty on the Materials. Buyer acknowledges that it is being given an opportunity to inspect the Materials, and that Seller has made no representations, warranties or covenants to Buyer concerning the value, condition or performance of the Materials. Except as set forth in Paragraph 1.1 above, Seller does not make, and has not made, any representations or warranties of any nature with respect to the Materials. THE MATERIALS ARE BEING SOLD TO BUYER AS IS, WHERE IS, AND WITH ALL FAULTS; AND SELLER HEREBY SPECIFICALLY DISCLAIMS ANY AND ALL WARRANTIES AND REPRESENTATIONS OF ANY NATURE WHATSOEVER, EXPRESS OR IMPLIED, WITH RESPECT TO THE MATERIALS, INCLUDING, WITHOUT LIMITATION, ANY IMPLIED WARRANTY OF MERCHANTABILITY OR FITNESS FOR A PARTICULAR PURPOSE, ANY WARRANTY ARISING BY COURSE OF DEALING OR USAGE OF TRADE AND ANY WARRANTY THAT THE MATERIALS ARE DELIVERED FREE OF RIGHTFUL CLAIM OF ANY THIRD PERSON BY WAY OF INFRINGEMENT OR THE LIKE.

1.3 Unless otherwise provided in this Agreement, the Project shall be delivered within 25 miles of Buyer's requested locations listed in Quote above. Regardless of shipping terms or freight payment, a third party transportation firm shall bear all risk of loss or damage in transit. Seller reserves the right to make delivery in installments, unless otherwise expressly stipulated herein. Delay in delivery of any installment shall not relieve Buyer of its obligations to accept remaining deliveries. Claims for shortages or other errors in delivery must be made in writing to Seller within 10 calendar days after receipt of shipment; and failure to give such notice shall constitute unqualified acceptance and a waiver of all such claims by Buyer. Claims for loss of or damage to Project in transit must be made to the carrier, and not to Seller. If third party carrier's cargo insurance fails to respond to a claim of damage to goods, Seller's contingent cargo coverage will respond. All delivery dates are approximate. Seller shall not be liable for any losses or damages as a result of any delay or failure to deliver due to any cause beyond Seller's reasonable control, including, but not limited to, any act of God, act of Buyer, embargo or other governmental act, regulation or request, fire, flood, accident, strike, slowdown, war, act of terrorism, riot, delay in transportation, equipment failure, or inability to obtain necessary labor or materials. In the event of any such delay, the date of delivery shall be extended for a period equal to the time lost because of the delay. Buyer's exclusive remedy for other delays and for Seller's inability to deliver for any reason shall be rescission of this Agreement.

1.4 Any manufacturer's tax, occupation tax, use tax, sales tax, excise tax, value added tax, duty, custom, inspection or testing fee, or any other tax, fee, interest or charge of any nature whatsoever imposed by any governmental authority on or measured by the transactions between Seller and Buyer shall be paid by Buyer in addition to the Purchase Price. In the event Seller is required to pay any such taxes or other charges, Buyer shall reimburse Seller therefor on demand.

1.5 All returnable containers and lifting brackets used in connection with shipments of the Project are the property of Seller and are loaned to Buyer. Buyer shall use such containers and/or brackets only for reasonable storage and/or offloading of the Project originally delivered and shall return such containers and/or brackets in good condition when empty or offloading is complete. Buyer will pay return freight charges on such empty containers and/or brackets from points in the continental United States of America. If brackets are not returned within 30 days, buyer agrees to purchase brackets at \$475.00 per set of four brackets or each single container.

1.6 Unless otherwise provided in this Agreement, Buyer shall be responsible for the construction, assembly or installation and proper maintenance of the Project.

## SECTION 2. LIMITATION OF LIABILITY

2.1 Unless otherwise provided in this Agreement, Seller's liability with respect to the Project shall be limited to the warranty of title set forth in Paragraph 1.1 above and, with respect to any breaches of such warranty, shall be limited to the portion of the Purchase Price allocable to the Project that are the subject of the breach. NONE OF SELLER, ITS AFFILIATES AND ITS CONTRACTORS SHALL BE SUBJECT TO ANY OTHER OBLIGATIONS OR LIABILITIES, WHETHER ARISING OUT OF BREACH OF CONTRACT, WARRANTY, TORT (INCLUDING NEGLIGENCE AND STRICT LIABILITY) OR UNDER OTHER THEORIES OF LAW OR EQUITY, WITH RESPECT TO THE PROJECT, OR ANY UNDERTAKINGS, ACTS OR OMISSIONS RELATING THERETO. NONE OF SELLER, ITS AFFILIATES AND ITS CONTRACTORS SHALL BE LIABLE FOR ANY CONSEQUENTIAL, INCIDENTAL, INDIRECT OR CONTINGENT DAMAGES WHATSOEVER AND HEREBY DISCLAIM ANY AND ALL SUCH DAMAGES. Without limiting the generality of the foregoing, each of Seller, its affiliates and its contractors specifically disclaims any liability for property damage, penalties, special or punitive damages, damages for lost profits or revenues, down-time, lost good will, cost of capital, cost of substitute goods or services, or for any other types of



QUO-9091





CellSite Solutions, LLC  
 CellSite Solutions, LLC  
 4150 C Street SW  
 Cedar Rapids IA 52404  
 United States

Quote  
 #QUO-9091  
 2/5/2024

economic loss, or for claims of Buyer's customers or any third party for any such damages, costs or losses.

SECTION 3. BUYER'S OBLIGATIONS CONCERNING THE PROJECT

3.1 Buyer shall be solely responsible for, and shall defend, indemnify and hold harmless Seller and its affiliates, and their respective directors, officers, employees, agents, insurers and other representatives (collectively, the "Seller Indemnified Parties"), from and against, any and all claims, demands, causes of action, losses, liabilities, damages, costs and expenses (including, without limitation, reasonable attorneys' fees and legal expenses) that directly or indirectly arise out of or result from the Project, or the transportation, construction, assembly, installation, use, maintenance or other possession or control of the Project by Buyer or its employees or agents or by third persons, or that otherwise directly or indirectly arise out of or result from any actual or alleged action or omission of Buyer or its agents or employees in connection with the Project. Seller may, at its sole election, participate in the defense of any such claims or causes of action at its own expense. Buyer agrees to keep Seller informed regarding all such claims and causes of action.

SECTION 4. MISCELLANEOUS

4.1 All proprietary and confidential information, including manufacturing or business information, supplied by Seller shall remain Seller's sole and exclusive property. Such information shall not be reproduced, used or disclosed to others by Buyer without Seller's prior written consent. Immediately upon termination of this Agreement, all confidential information together with any copies thereof shall be returned to Seller.

4.2 This Agreement constitutes the entire agreement, superseding all prior oral or written negotiations, representations, understandings and agreements, between the parties on the subject matter hereof; and there are no conditions to this Agreement which are not expressed herein. No terms which may be contained in any of Buyer's purchase order, acknowledgment or other forms or correspondence, whether additional to or different from those in this Agreement, shall be of any force or effect with respect to the subject matter hereof.

4.3 Neither party shall assign or transfer this Agreement, or its rights or obligations under this Agreement, in whole or in part, voluntarily or by operation of law, without the prior written consent of the other party, and any attempted assignment or transfer without such consent shall be void and without effect.

4.4 No term or provision of this Agreement shall be deemed waived and no breach excused, unless such waiver or consent shall be in writing and signed by the party claimed to have waived or consented. Any consent by any party to, or waiver of, a breach by the other, shall not constitute a consent to, waiver of, excuse of any other different or subsequent breach.

4.5 In the event that any of the provisions of this Agreement shall be held to be illegal, invalid or unenforceable as a matter of law, the same shall not invalidate this Agreement which shall be construed as if not containing such provision and the rights and obligations of the parties shall be construed and enforced as if a commercially reasonable provision had been substituted in place thereof, consistent with the undertakings of the parties hereto.

4.6 This Agreement may be executed by facsimile or electronic signatures and in one or more counterparts. Each such counterpart shall be considered an original and all of such counterparts shall constitute a single agreement binding all the parties as if all had signed a single document.

4.7 In the event that Seller is required, or chooses, to enforce the terms of this Agreement in litigation, whether as plaintiff or defendant, Buyer shall reimburse Seller for its actual costs incurred in such enforcement, including, but not limited to, reasonable attorneys' fees and legal expenses. Any action arising out of or relating to this Agreement shall be determined exclusively by the Circuit Court for Linn County, Iowa or the U.S. District Court for the Northern District of Iowa and, in the event of an appeal or petition for review or certiorari, by the courts having jurisdiction to review the decisions of the courts specifically identified above. Buyer consents to in personam jurisdiction and to venue exclusively in said courts; and Buyer hereby appoints the Secretary of State of Iowa as its agent for service of process in Iowa.

4.8 This Agreement shall be governed by and construed in accordance with the laws, without reference to principles of conflicts of laws, of the State of Iowa.

The shelter Lifting Hardware, which includes bolts and brackets to be provided for buyers use.

Following delivery and offload, lifting brackets to be mailed to Cellsite Solutions, LLC (Cedar Rapids, IA) at buyer's expense;

Exact Shipping Address:

\_\_\_\_\_  
 \_\_\_\_\_  
 \_\_\_\_\_

Lats: \_\_\_\_\_ Longs: \_\_\_\_\_



QUO-9091



CellSite Solutions, LLC  
 CellSite Solutions, LLC  
 4150 C Street SW  
 Cedar Rapids IA 52404  
 United States

Quote  
 #QUO-9091  
 2/5/2024

IN WITNESS WHEREOF, the parties have hereunto executed this Agreement by their duly authorized agents as of the date first above written.

Hunt County  
 ("BUYER")  
 By: [Signature]  
 Printed Name: Bobby W. Stovall  
 Title: Hunt County Judge  
 Date: 2-13-24  
 Quote#/P.O. \_\_\_\_\_

CELLSITE SOLUTIONS, LLC  
 ("SELLER")  
 By: \_\_\_\_\_  
 Printed Name: \_\_\_\_\_  
 Title: \_\_\_\_\_  
 Date: \_\_\_\_\_



18,623-5

at 2:00 o'clock P M

FEB 13 2024

BECKY LANDRUM  
County Clerk, Hunt County, Tex.

HUNT COUNTY  
BID AWARD  
FORMAL BID #244-24, RECYCLED ASPHALT AND CONCRETE  
UNDELIVERED / DELIVERED  
Effective 2/12/24 through 2/11/25

PRECINCT	VENDOR	RECYCLED ASPHALT PER TON UNDELIVERED	RECYCLED CONCRETE PER TON UNDELIVERED	RECYCLED ASPHALT - CONCRETE PER TON DELIVERED	Pick - Up Point	INTERLOCAL ALLOWED
Precinct 1	Big City Crushed Concrete*	\$15.00	\$16.00	\$34.00 (Recycled Asphalt) & \$35.00 (Recycled Concrete)	11143 Goodnight Ln, Dallas, TX 75229; 2nd location: 1005 Forest Ave. Dallas, TX 75215 (call for availability) Dallas, TX 75229	Yes (FOB only)
Precinct 2	Big City Crushed Concrete*	\$15.00	\$16.00	\$32.00 (Recycled Asphalt) & \$33.00 (Recycled Concrete)	11143 Goodnight Ln, Dallas, TX 75229; 2nd location: 1005 Forest Ave. Dallas, TX 75215 (call for availability) Dallas, TX 75229	Yes (FOB only)
Precinct 3	Big City Crushed Concrete*	\$15.00	\$16.00	\$36.50 (Recycled Asphalt) & \$37.50 (Recycled Concrete)	11143 Goodnight Ln, Dallas, TX 75229; 2nd location: 1005 Forest Ave. Dallas, TX 75215 (call for availability) Dallas, TX 75229	Yes (FOB only)
Precinct 4	Big City Crushed Concrete*	\$15.00	\$16.00	\$37.50 (Recycled Asphalt) & \$38.50 (Recycled Concrete)	11143 Goodnight Ln, Dallas, TX 75229; 2nd location: 1005 Forest Ave. Dallas, TX 75215 (call for availability) Dallas, TX 75229	Yes (FOB only)
All Precincts	Arcosa Crushed Concrete**	\$23.00	\$20.00/ton pickup point Mckinney; \$19.00/ton pickup point Garland; \$19.00/ton pickup point Hutchins; \$20.00/ton pickup point Sunnvale	NO BID	3637 Castle Dr., Garland, TX 75046_2540 E. University Dr., Mckinney, TX 75069_1000 Interstate HWY 20, Hutchins, TX 75141_200 N Lawson Rd, Mesquite, TX 75182	Yes

HUNT COUNTY  
BID AWARD

FORMAL BID #244-24, RECYCLED ASPHALT AND CONCRETE  
UNDELIVERED / DELIVERED

Effective 2/12/24 through 2/11/25

The Purchasing Department recommends award of this bid to all bidders in accordance with Local Government Code §262.027 (e)

\*\*Arcosa Crushed Concrete does not guarantee material quality or quantity.

\*\*Inventory is not guaranteed.

\*\*Fixed Base is produced from recycled crushed concrete.

All prices are FOB Pick-up Points from all vendors.



18,623-8

FILED FOR RECORD  
at 2:00 o'clock P M

FEB 13 2024

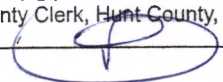
BECKY LANDRUM  
County Clerk, Hunt County, Tex.  
By 



# COUNTY & DISTRICT CLERKS' ASSOCIATION OF TEXAS

Certificate of Completion Awarded to

Susan Spradling

Hunt County, District Clerk

*For completing the required 20 Hours of Continuing Education for 2023 as  
prescribed in Section 51.605 of the Texas Government Code.*

*In Witness therefore, recognition is hereby made this January 2024.*



Julie Smith, President



John Warren, Vice President



**ITEM 5.** Form numbers of Endorsements Forming Part of this **Policy** When Issued:  
SEE FORM GU207 (SCHEDULE OF ENDORSEMENTS)

---

**ITEM 6.** Cancellation of Prior Insurance: By acceptance of this **Policy** the "Insured" gives the Insurer notice cancelling prior policies or bonds numbered: FA 02285832301 the cancellations to be effective at the time this **Policy** becomes effective.

---

**ITEM 7. ADDRESS FOR NOTICES TO THE INSURER**

**(A) For Claims:**

The Hartford  
Hartford Financial Lines  
One Hartford Plaza  
Hartford, CT 06115

[HFPClaims@thehartford.com](mailto:HFPClaims@thehartford.com)  
Fax: (917) 464-6000

**(B) For other than Claims:**

The Hartford  
Hartford Financial Lines  
One Hartford Plaza  
Hartford, CT 06115

[HFPEXpress@thehartford.com](mailto:HFPEXpress@thehartford.com)  
Fax: (866) 586-4550



---

**Authorized Representative**

02/04/2024

---

**Date**



## ENDORSEMENT

This endorsement, effective on 02/19/2024 at 12:01 A.M standard time, forms a part of

Policy No. 46 FA 0228583-24 of the HARTFORD FIRE INSURANCE CO.

Issued to HUNT COUNTY OFFICE OF TAX COLLECTOR ASSESSOR



Ross Fisher, President

### SCHEDULE

---

	CA00H12601	2/15	BOND BILLING STATEMENT
	CA00H00200	9/09	CRIMESHIELD ADVANCED POLICY DECLARATIONS
	CA00H00300	9/09	THE HARTFORD CRIMESHIELD ADVANCED POLICY
	RN00U00100	5/93	IN WITNESS PAGE
1	HG00H00901	7/08	AMEND MAILING ADDRESS FOR NOTICE ENDORSEMENT
2	CA00H09300	9/09	AMENDMENT FOR GOVERNMENTAL ENTITIES
3	CA00H09401	11/12	AMENDMENT FOR GOVERNMENTAL ENTITIES - INCLUDES COVERAGE FOR BONDED EMPLOYEES, TREASURERS
4	CA00H15500	10/14	DECEPTION FRAUD ENDORSEMENT
5	CA00H15900	2/15	GOVERNMENTAL ENTITIES WITH INSURING AGREEMENT 12 AMEND EXCLUSION
6	CA00H15600	10/14	INCLUDE COVERAGE FOR VIRTUAL CURRENCY - SUBLIMITED
7	CA00H01600	9/09	SPECIFIC ENTITY EXCLUSION
8	CA42H00400	9/09	TEXAS AMENDATORY ENDORSEMENT
9	CA42H00500	9/09	TEXAS CANCELLATION AND NONRENEWAL ENDORSEMENT
10	CA42H00600	11/10	TEXAS NOTICE
	HG00H12900	10/16	U.S. DEPARTMENT OF THE TREASURY, OFFICE OF FOREIGN ASSETS CONTROL ("OFAC")
	HR42H00601	6/23	TEXAS IMPORTANT NOTICE
	HR00H09300	2/07	PRODUCER COMPENSATION NOTICE
11	CA00H01600	9/09	SPECIFIC ENTITY EXCLUSION

This endorsement, effective 12:01 am, 02/19/2024

of policy number 46 FA 0228583-24

issued to: HUNT COUNTY OFFICE OF TAX COLLECTOR ASSESSOR

by: HARTFORD FIRE INSURANCE CO.

**THIS ENDORSEMENT CHANGES THE POLICY. PLEASE READ IT CAREFULLY.**

**DECEPTION FRAUD ENDORSEMENT**

This endorsement modifies insurance provided under the following:

**THE HARTFORD CRIMESHIELD® ADVANCED POLICY**

I. Section II. **INSURING AGREEMENTS**, is amended by the addition of the following:

**DECEPTION FRAUD**

The Insurer will pay for loss of "money" or "securities" resulting from "deception fraud," subject to the Limit of Insurance and Deductible stated in the SCHEDULE below.

**Deception Fraud SCHEDULE**

<b>Limit of Insurance</b>	<b>\$15,000</b>	<b>Retention</b>	<b>\$5,000</b>
---------------------------	-----------------	------------------	----------------

The above Limit of Insurance and Deductible apply per "occurrence."

II. Section V. **DEFINITIONS**, is amended by the addition of the following:

- *"Deception Fraud"* means the intentional misleading of a person to induce the "Insured" to part with "money" or "securities" by someone pretending to be an "employee," owner of the "Insured" or one of the following business relations:
  1. A "vendor;"
  2. A "customer;"
  3. A "custodian;" or
  4. A "messenger."
- *"Customer"* means a natural person or entity for whom the "Insured" provides goods or services.
- *"Vendor"* means a business entity that sells goods or services to the "Insured."

III. Section VI. **EXCLUSIONS**, is amended in the following manner:

1. Exclusion C. is deleted and replaced with the following:

Loss resulting from "theft," "deception fraud" or any other dishonest or criminal act committed by any of the "Insured's" "employees", managers, directors, trustees or representatives whether acting alone or in collusion with other persons or while performing services for the "Insured" or otherwise except when covered under INSURING AGREEMENT 1. – EMPLOYEE THEFT or INSURING AGREEMENT 2. – EMPLOYEE THEFT – CLIENT PREMISES.



HARTFORD FIRE INSURANCE CO.

**Date:** 2/4/2024

**Producer Code:** 46511945

F5 INSURANCE SOLUTIONS LLC  
6905 STONEWALL STREET  
GREENVILLE, TX 75402

**Producer's Advice of Premium for Fidelity**

**Insured:** HUNT COUNTY OFFICE OF TAX COLLECTOR ASSESSOR  
**Policy #:** 46 FA 0228583-24  
**Policy Term:** 02/19/2024 - 02/19/2025  
**Type of Policy:** CRIMESHIELD ADVANCED  
**Billing Term:** ANNUAL  
**Billing Type:** HFP BILL  
**Transaction Type:** RENEWAL

Premium
\$ 11,865

**Comments:**

PLEASE NOTE THAT THIS IS A PRODUCER'S ADVICE OF PREMIUM ONLY. AN ORIGINAL INVOICE WILL BE SENT DIRECTLY TO YOUR ACCOUNTING DEPARTMENT.

THE STATE OF TEXAS

COUNTY OF HUNT

I hereby certify that this instrument was FILED on the date and the time stamped hereon by me and was duly RECORDED in the Records of HUNT County, Texas.

2024-02013 BOND  
02/05/2024 09:48 AM



*Becky Landrum*

Becky Landrum, County Clerk  
Hunt County, TX

18,623-11



FILED FOR RECORD  
at 2:00 o'clock P M

FEB 13 2024

BECKY LANDRUM  
County Clerk, Hunt County, Tex.  
By

01/31/2024  
Pearce Services  
1222 Vine St., Ste 301  
Paso Robles, CA 93446

**Bore/Duct Installation/ HH PL/DB PL**

Greetings,

Frontier Communications is requesting permission to bore 9028' to place 6539' of (1)-1.25" duct, 2487' of (2)-1.25" ducts, place (16) 17"X30" HH, (13) 2'X3' HH, and (18) 11"X11"X16" drop box. This request is for road crossings on CR 3602. **Project # 5295349** (SR-352345).

Please, see the attached construction package for location and proposed work details. If you have any questions, please contact me at any time.

Sincerely,

Darrin Albrecht  
Manager, FTTH Quality Control  
Central Region  
Darrin.l.albrecht@ftr.com  
281-229-0849

Submitted by:  
Rodney Doyal  
Permit Specialist, Pearce Services  
[rodney.doyal@pearce-services.com](mailto:rodney.doyal@pearce-services.com)

*County Approval Section:*

Approved: \_\_\_\_\_

Denied: \_\_\_\_\_

Authorized Signature: \_\_\_\_\_ Date: \_\_\_\_\_

**FRONTIER COMMUNICATION  
CONSTRUCTION SPECIFICATIONS**

- Contact Frontier Engineer DARRIN ALBRECHT at (281) 229-0849 sixty (60) days prior to need of service in order to confirm compliance, order materials, and schedule work forces. NOTE: FRONTIER COMMUNICATIONS, INCORPORATED, RESERVES THE RIGHT TO REFUSE ANY CONDUIT, PULL BOXES, MANHOLES, OR UTILITY BOXES THAT DEVIATE FROM PLANS AND SPECIFICATIONS.
- All conduit riser bends to have a minimum thirty-six (36) inch radius.
- All horizontal ninety (90) degree bends shall have a minimum radius of 12.5 feet and all vertical ninety (90) degree bends shall have a minimum radius of three feet. No more than two ninety (90) degree horizontal bends shall be placed in any single run unless otherwise specified. Contact the Frontier engineer concerning any required deviations.
- All conduit must be proven using a manhole no less than a 1/2" smaller than the conduit placed. Wall to wall measurements must be taken with a measured tape and a 3/8" polypropylene pull rope in each duct. An accurate wall to wall measurement of conduit placed must be As-built on an approved Frontier construction plan. A copy of the As-built conduit work order must be provided to the Frontier Inspector assigned to your project.
- Place weatherproof caps on all terminated conduits.
- Approved plastic conduit (PVC Sch. 40, TYPE-C or HDPE (2") is to be used in underground construction unless otherwise specified.
- Conduit terminated on a pole must be PVC Sch. 80. Location of riser on pole will be called out by engineering on the construction plan.
- Conduit placed in same trench with primary power conduit must be separated by a minimum of twelve (12) inches of well-packed sand or three inches of concrete, and have a minimum of thirty-six (36) inches of cover when placed behind curb face. All street crossings and conduits placed in the driven portion of the roadway must have a minimum of forty-eight (48) inches of cover to top of pipe. CONTACT THE FRONTIER INSPECTOR 48 HOURS BEFORE TRENCHING AND UPON COMPLETION OF YOUR SUBSTRUCTURES TO SCHEDULE THE FINAL INSPECTION.

**PERMITTING AGENCY:  
HUNT COUNTY  
(CR-3602)**

**PICK UP POINT:  
PVT RD 3642 LIMITS**

**PATH FOOTAGE:  
BORE = 9028'**

**MATERIALS:  
(18) NEW 17"x30" MH  
(13) NEW 22"x3" MH  
(18) NEW 11"x11"x18" DROP BOX  
8536' OF (1)-1.25" DUCT  
2487' OF (2)-1.25" DUCTS**



**Know what's below.  
Call before you dig.**

# CONSTRUCTION PACKAGE

**FDH - 9052 CO RD 3602  
PVT RD-3842 & CR-3602  
QUINLAN, TX 75474**

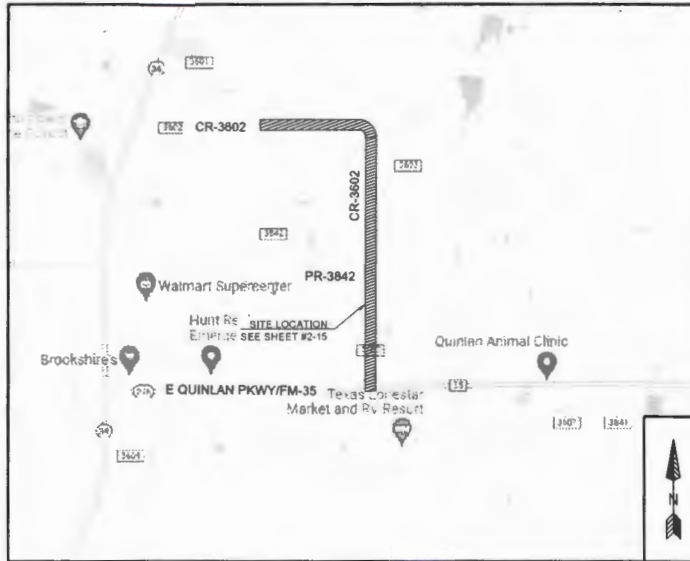

**VICINITY MAP  
NTS**

-HDPE AND PVC FOOTAGES DO NOT INCLUDE SWEEPS  
-ACTUAL FOOTAGES OF HDPE AND PVC WILL BE NEEDED TO ORDER MATERIALS. PLEASE INCLUDE MEASURED TAPE IN ALL PKCS.  
-FRONTIER INSPECTOR SHALL BE PRESENT ON SITE WHEN CONTRACTOR NEEDS TO ACCESS ANY EXISTING FRONTIER FACILITY.

**ABBREVIATIONS**

BLDG	BUILDING	PED	PEDESTAL (UTILITY)
CL	CENTER LINE	PVC	POLYVINYL CHLORIDE
CONC	CONCRETE	P/L	PROPERTY LINE
CSW	CONCRETE SIDEWALK	RR	RAILROAD
DWY	DRIVEWAY	R/W	RIGHT OF WAY
ECC	EDGE OF CURB	SL	STREET LIGHT
EOP	EDGE OF PAVEMENT	W-BLDG	WALL TO BUILDING
ETW	ETW LINE	W-P	WALL TO POLE
HH	HANDHOLE	W-W	WALL TO WALL
MH	MANHOLE	P.U.E.	PUBLIC UTILITY EASEMENT
NTS	NOT TO SCALE	P.S.E.	PUBLIC SERVICE EASEMENT
		C/G	CURB & GUTTER

**LEGEND**

	New Trench
	New Bore
	Existing Gas
	Existing Water
	Existing Telephone
	Existing Sewer
	Existing Storm Drain
	Existing Electric
	Existing Manhole
	Existing Handhole (2'x3' or 17'x30')
	OSLAM
	X-CONNECT
	POWER PEDESTAL
	TELECO PEDESTAL
	3' x 5' PULL BOX
	POLE



JOB ID: 5295349	DATE: 12/06/2022
TITLE: FDH - 9052 CO RD 3602	
STREET ADDRESS: 9052 CO RD 3602	
CITY/STATE: QUINLAN, TX 75474 (HUNT COUNTY)	
FTR ENGINEER: DARRIN ALBRECHT (281) 229-0849	
FTR INSPECTOR: JAMES WEST (972) 578-3224	
 CHC CONSULTING ENGINEERED BY JIM CORTEZ, INC. LLC 5414 W. SANDHURST DR. STE 100 DALLAS, TX 75248	DRAWN BY CHC CONSULTING EST. #: SHEET # 1 OF 16

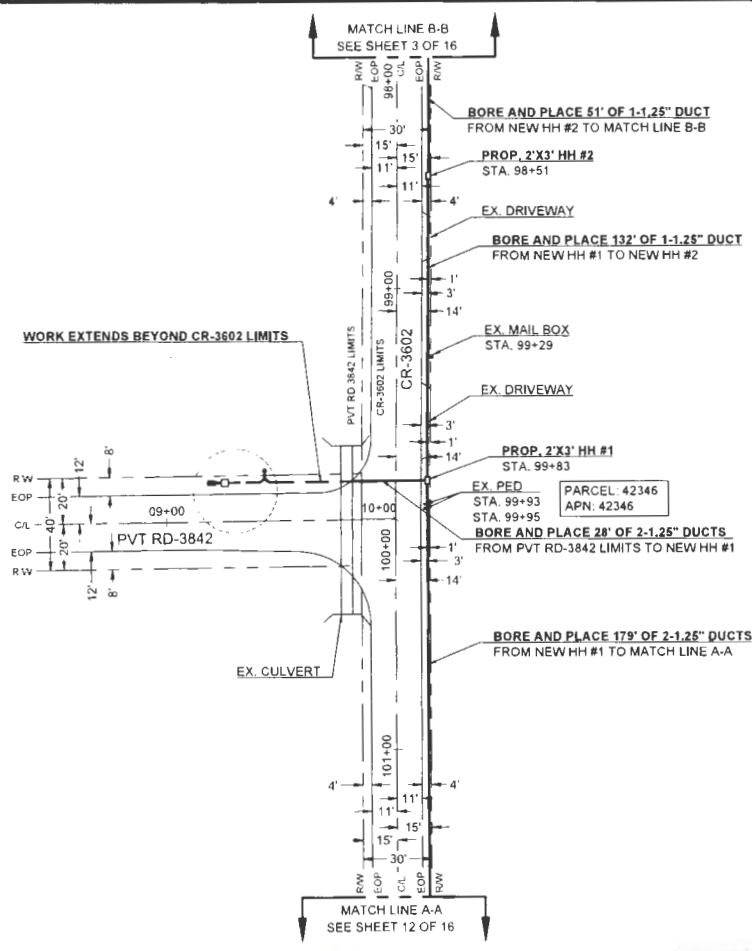

CURVE	RADIUS	LENGTH	DELTA
C1	3'	5'	90°

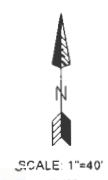

Know what's below.  
Call before you dig.

**Frontier COMMUNICATIONS**

JOB ID: 5295349      DATE: 12/05/2022

TITLE: FDH - 9052 CO RD 3602

STREET ADDRESS: 9052 CO RD 3602

CITY/STATE: DUBLIN, TX 75474 (HUNT COUNTY)

FTR ENGINEER: DARRIN ALBRECHT (281) 229-0849

FTR INSPECTOR: JAMES WEST (972) 578-3224

DRAWN BY: CHC CONSULTING

EST. #

SHEET #

2 OF 13

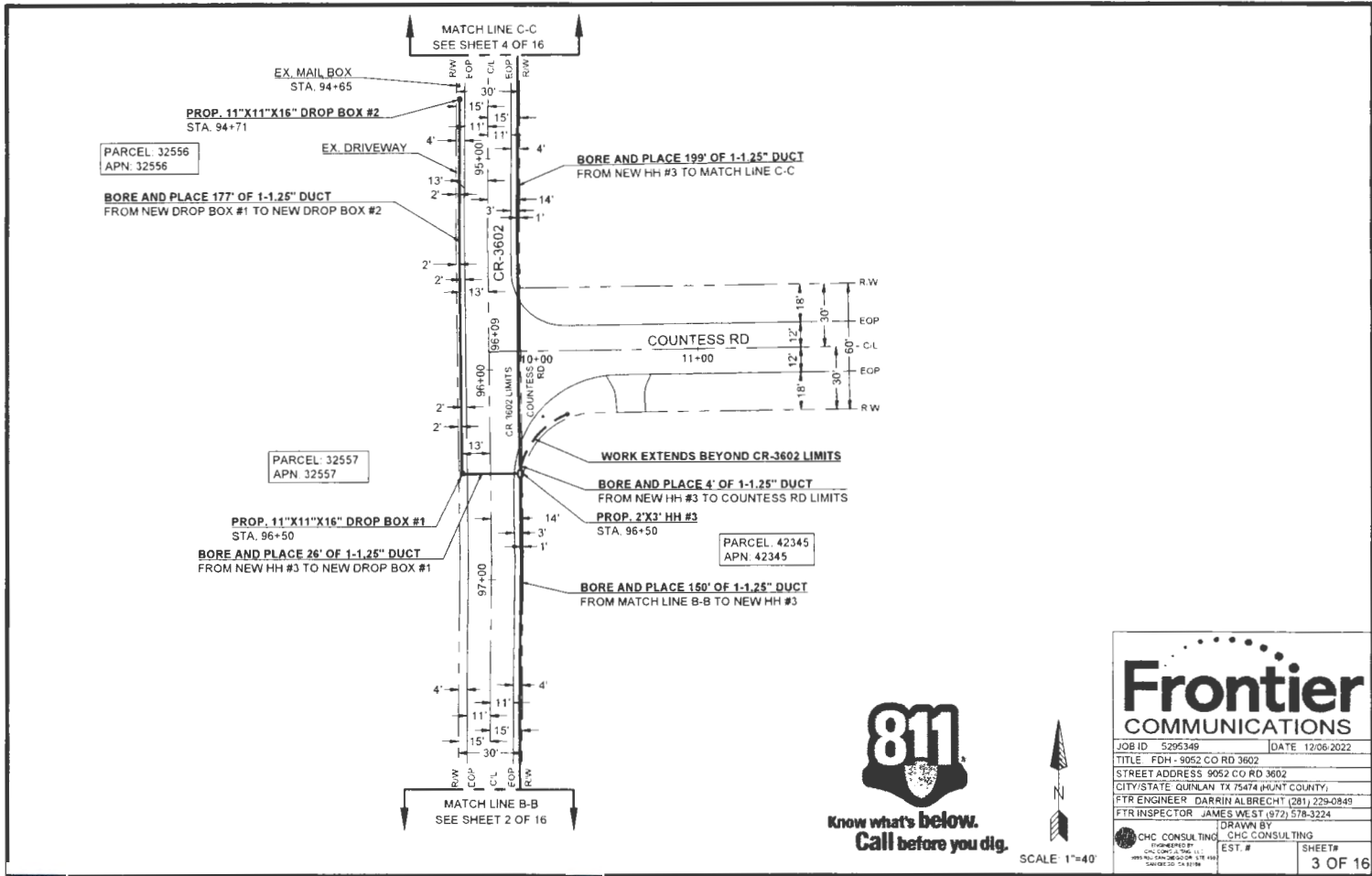

**811**  
 Know what's below.  
 Call before you dig.

SCALE 1"=40'

**Frontier COMMUNICATIONS**

JOB ID 5295349	DATE 12/06/2022
TITLE FDH - 9052 CO RD 3602	
STREET ADDRESS 9052 CO RD 3602	
CITY/STATE QUINLAN TX 75474 (HUNT COUNTY)	
FTR ENGINEER DARRIN ALBRECHT (281) 229-0849	
FTR INSPECTOR JAMES WEST (972) 578-3224	
CHC CONSULTING <small>INCORPORATED BY          CHC CONSULTING, INC.          1999 10111 CANAL DRIVE SUITE 110          DALLAS TEXAS 75244</small>	DRAWN BY CHC CONSULTING EST. # SHEET#
	<b>3 OF 16</b>



MATCH LINE D-D  
SEE SHEET 5 OF 16

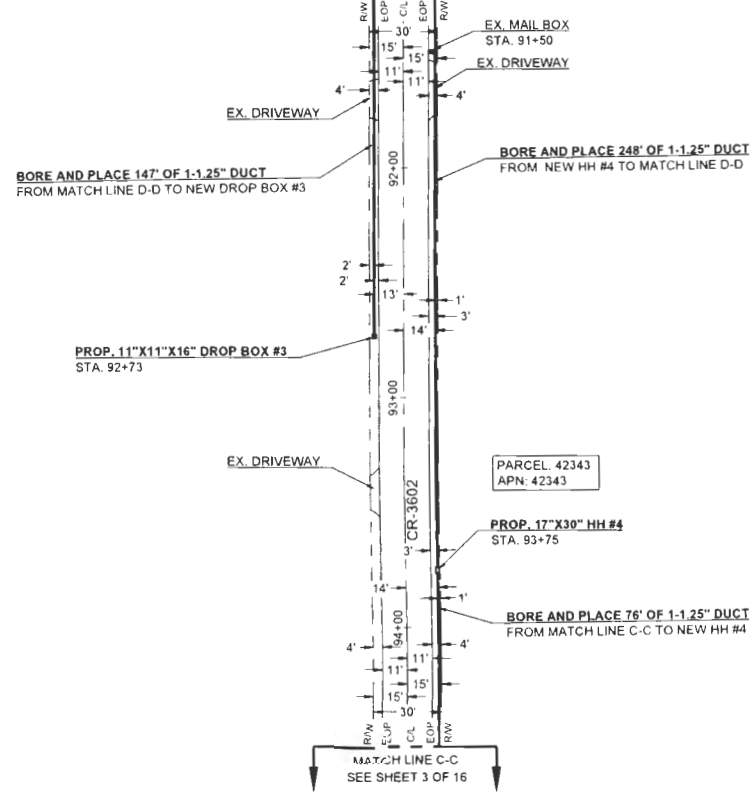

SCALE 1"=40'



Know what's below.  
Call before you dig.

# Frontier COMMUNICATIONS

JOB ID 5295349	DATE 12/06/2022
TITLE FDH - 9052 CO RD 3602	
STREET ADDRESS 9052 CO RD 3602	
CITY/STATE QUINLAN, TX 75474 (HUNT COUNTY)	
FTR ENGINEER DARRIN ALBRECHT (281) 229-0849	
FTR INSPECTOR JAMES WEST (972) 578-3224	
 CHC CONSULTING <small>ENGINEERED BY THE LON LA BING, L.L.C. PWS REG. NO. 00000209-000-000 DAYS DEL. CO. 01-19-18</small>	DRAWN BY CHC CONSULTING EST. # SHEET#
	4 OF 16

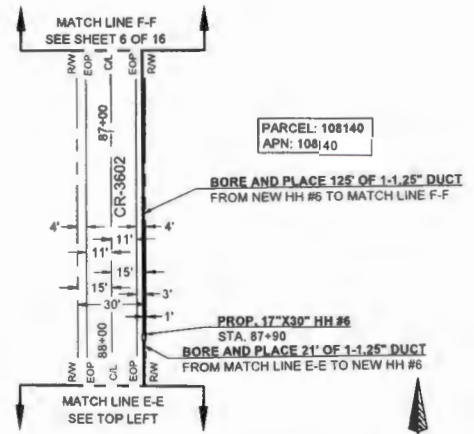
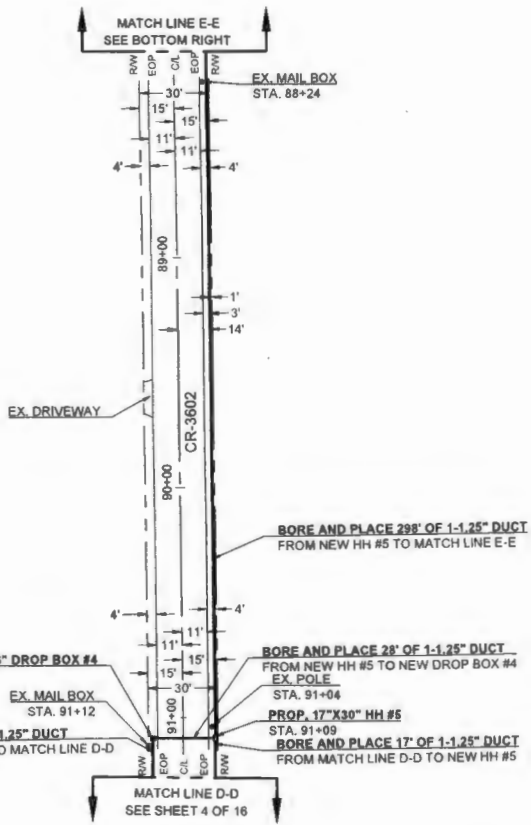

**811**  
Know what's below.  
Call before you dig.

SCALE 1"=40'

**Frontier**  
COMMUNICATIONS

JOB ID: 5295349	DATE: 12/06/2022
TITLE: FDH - 9052 CO RD 3602	
STREET ADDRESS: 9052 CO RD 3602	
CITY/STATE: QUINLAN TX 75474 (HUNT COUNTY)	
FTR ENGINEER: DARRIN ALBRECHT (281) 229-0949	
FTR INSPECTOR: JAMES WEST (972) 578-3224	
CHC CONSULTING <small>CHC CONSULTING, L.L.C.          10000 LAWRENCE ST. STE 100          SAN ANTONIO, TX 78240</small>	DRAWN BY: CHC CONSULTING EST. # _____ SHEET # _____

**5 OF 16**

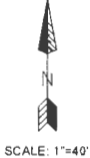
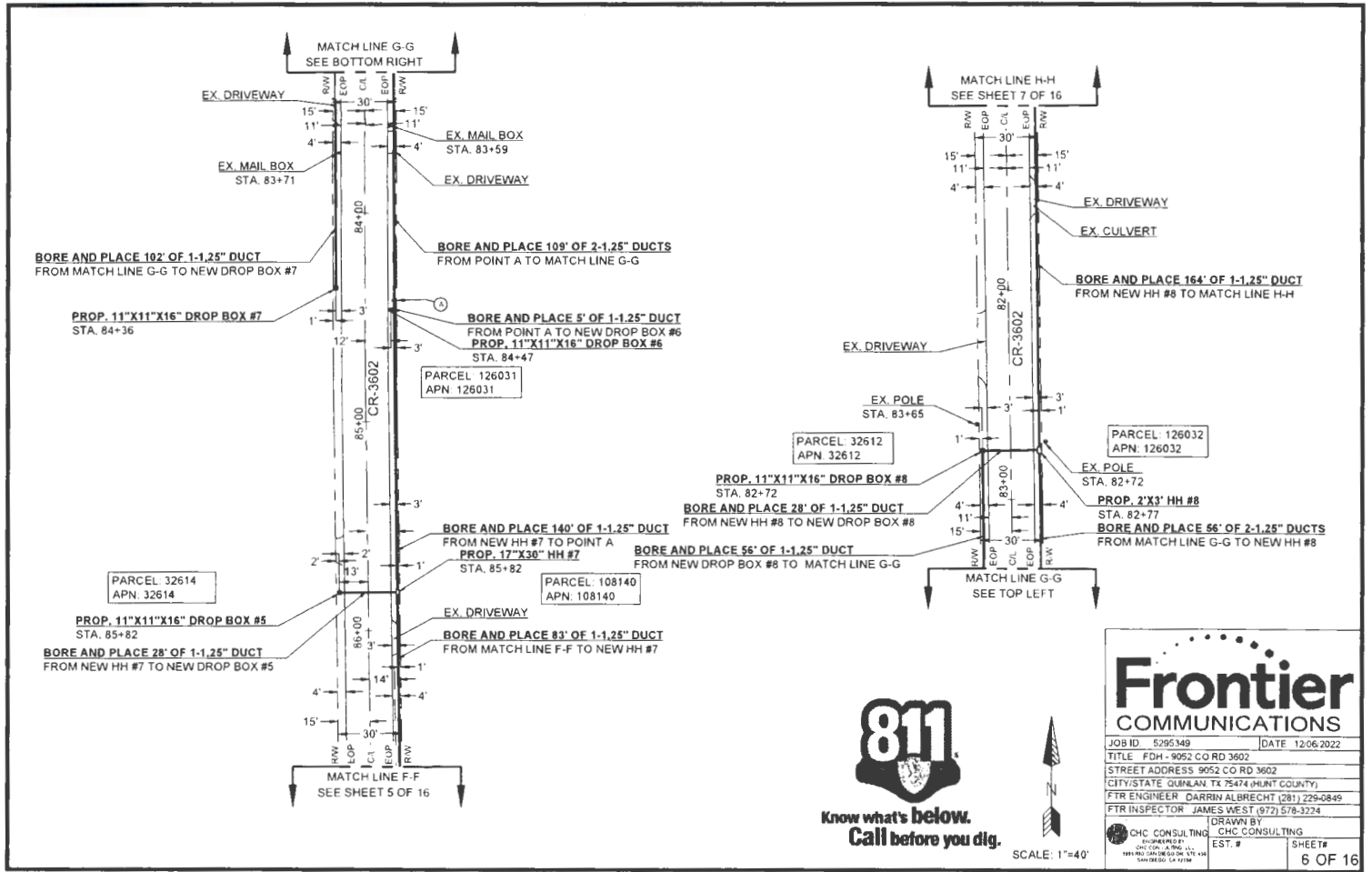

**Frontier COMMUNICATIONS**

JOB ID: 5295349      DATE: 12/06/2022

TITLE: FDH - 9052 CORD 3602

STREET ADDRESS: 9052 CORD 3602

CITY/STATE: DUNHAM, TX 75474 (HUNT COUNTY)

FTR ENGINEER: DARRIN ALBRECHT (281) 229-0849

FTR INSPECTOR: JAMES WEST (972) 578-3224

CHC CONSULTING INCORPORATED 2015 COLLEGE BLVD, SUITE 100 DALLAS, TEXAS 75206	DRAWN BY CHC CONSULTING
EST. #	SHEET #
	6 OF 16



Know what's below.  
Call before you dig.

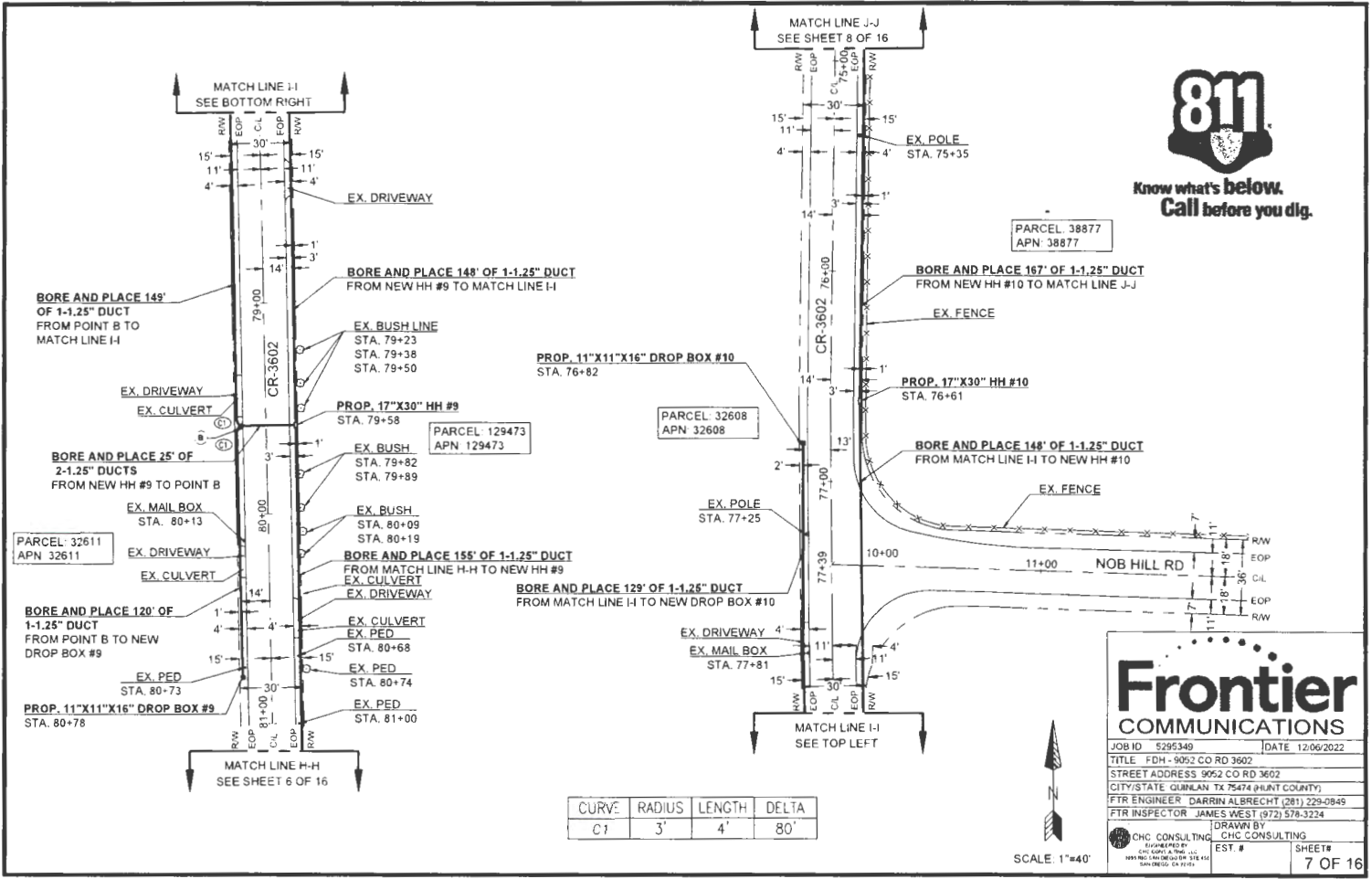

PARCEL 38877  
APN 38877

PARCEL 129473  
APN 129473

PARCEL 32608  
APN 32608

PARCEL 32611  
APN 32611

CURVE	RADIUS	LENGTH	DELTA
C1	3'	4'	80'

# Frontier COMMUNICATIONS

JOB ID 5295349      DATE 12/06/2022  
 TITLE FDH - 9052 CO RD 3602  
 STREET ADDRESS 9052 CO RD 3602  
 CITY/STATE QUINLAN TX 75474 (HUNT COUNTY)  
 FTR ENGINEER DARRIN ALBRECHT (281) 229-0949  
 FTR INSPECTOR JAMES WEST (972) 578-3224  
 DRAWN BY CHC CONSULTING  
 EST. # SHEET#  
 7 OF 16

SCALE: 1"=40'



Know what's below.  
Call before you dig.

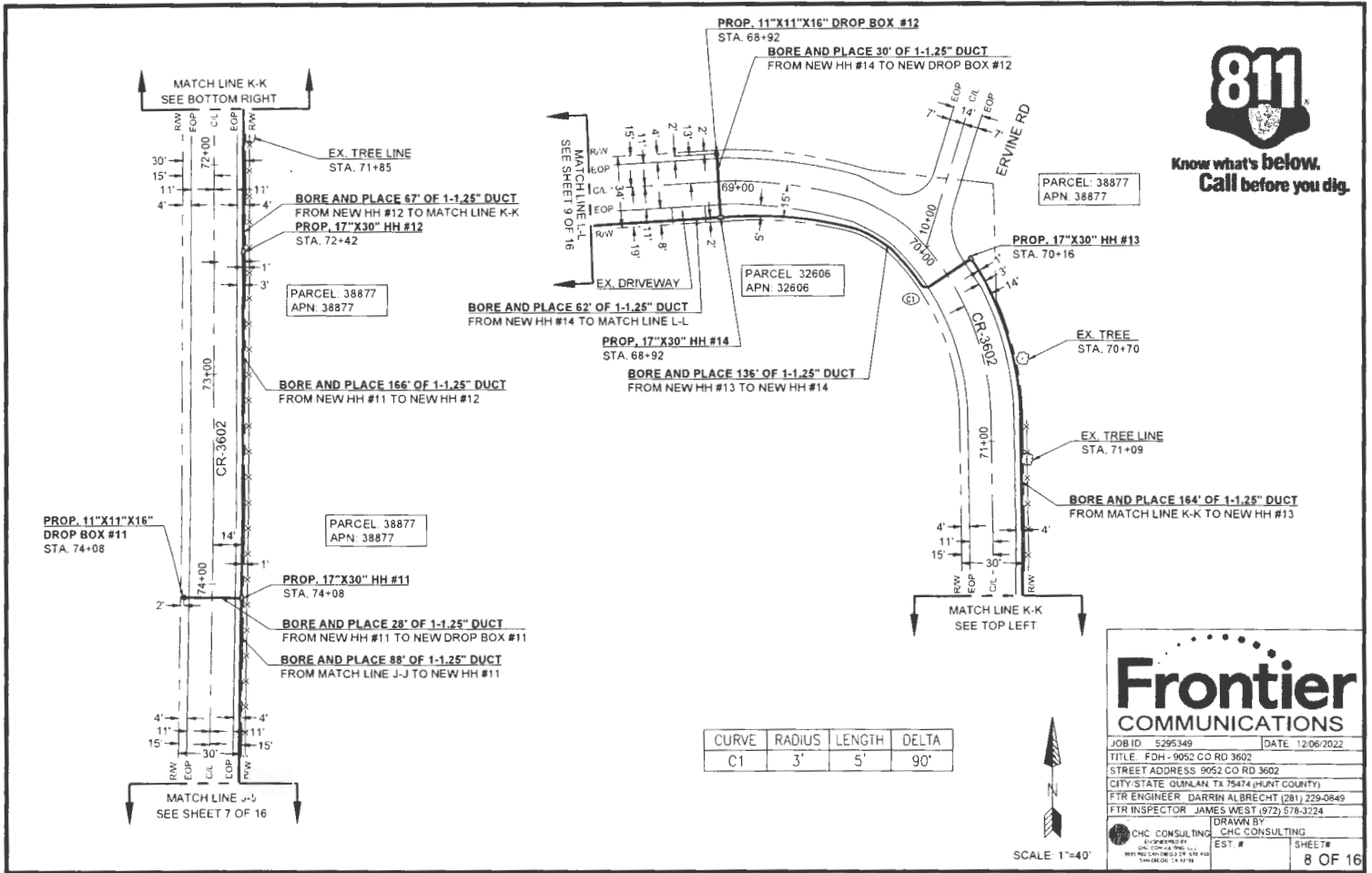

CURVE	RADIUS	LENGTH	DELTA
C1	3'	5'	90°

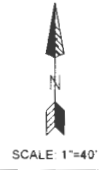

**Frontier COMMUNICATIONS**

JOB ID: 5295349      DATE: 12/06/2022

TITLE: FDH - 9952 CO RD 3602

STREET ADDRESS: 9952 CO RD 3602

CITY/STATE: OULINAN, TX 75474 (HUNT COUNTY)

FTR ENGINEER: DARRIN ALBRECHT (281) 229-0849

FTR INSPECTOR: JAMES WEST (972) 578-3224

DRAWN BY: CHC CONSULTING

EST. #      SHEET #

8 OF 16

CURVE	RADIUS	LENGTH	DELTA
C1	3'	5'	90°

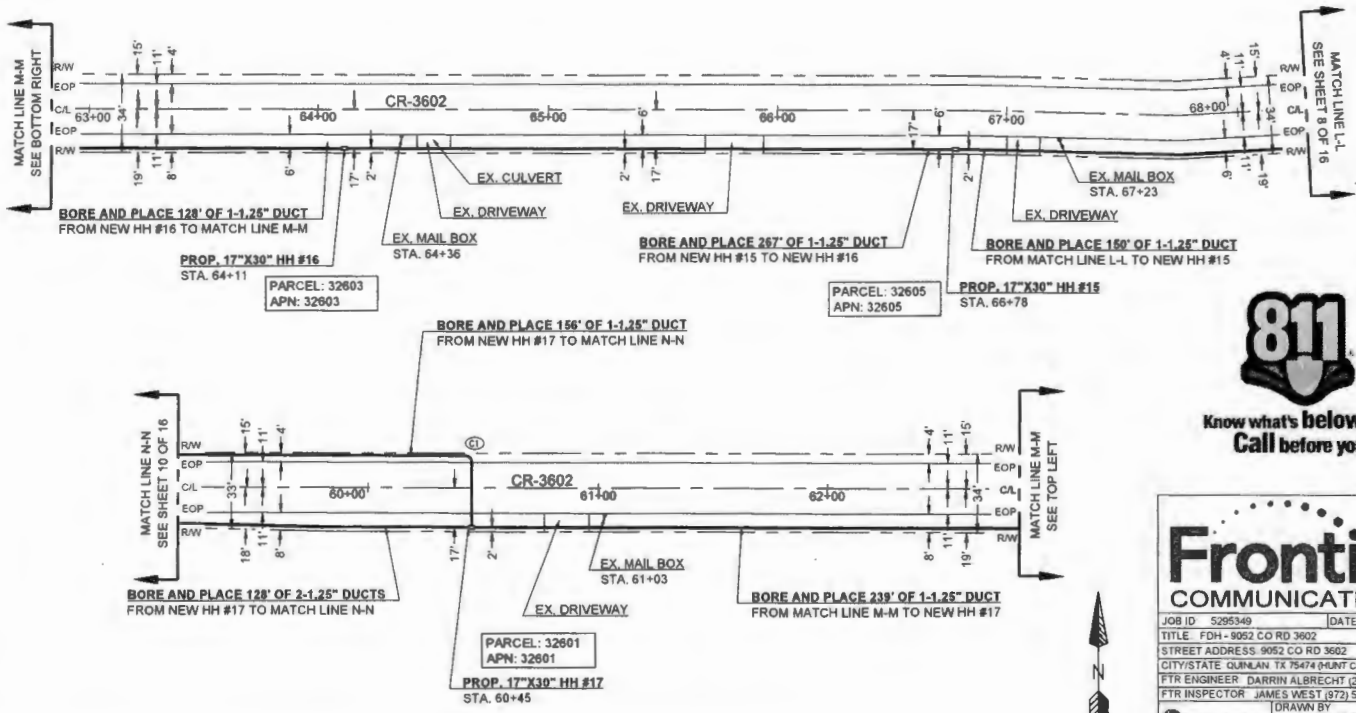

Know what's below.  
Call before you dig.

**Frontier COMMUNICATIONS**

JOB ID: 5295349      DATE: 12/06/2022

TITLE: FDH - 9052 CO RD 3602

STREET ADDRESS: 9052 CO RD 3602

CITY/STATE: QUINLAN TX 75074 (HUNT COUNTY)

FTR ENGINEER: DARRIN ALBRECHT (281) 225-0849

FTR INSPECTOR: JAMES WEST (872) 578-3224

DRAWN BY: CHC CONSULTING

EST. #      SHEET#

9 OF 16

SCALE: 1"=40'

CURVE	RADIUS	LENGTH	DELTA
C1	3'	3'	58°
C2	3'	5'	90°

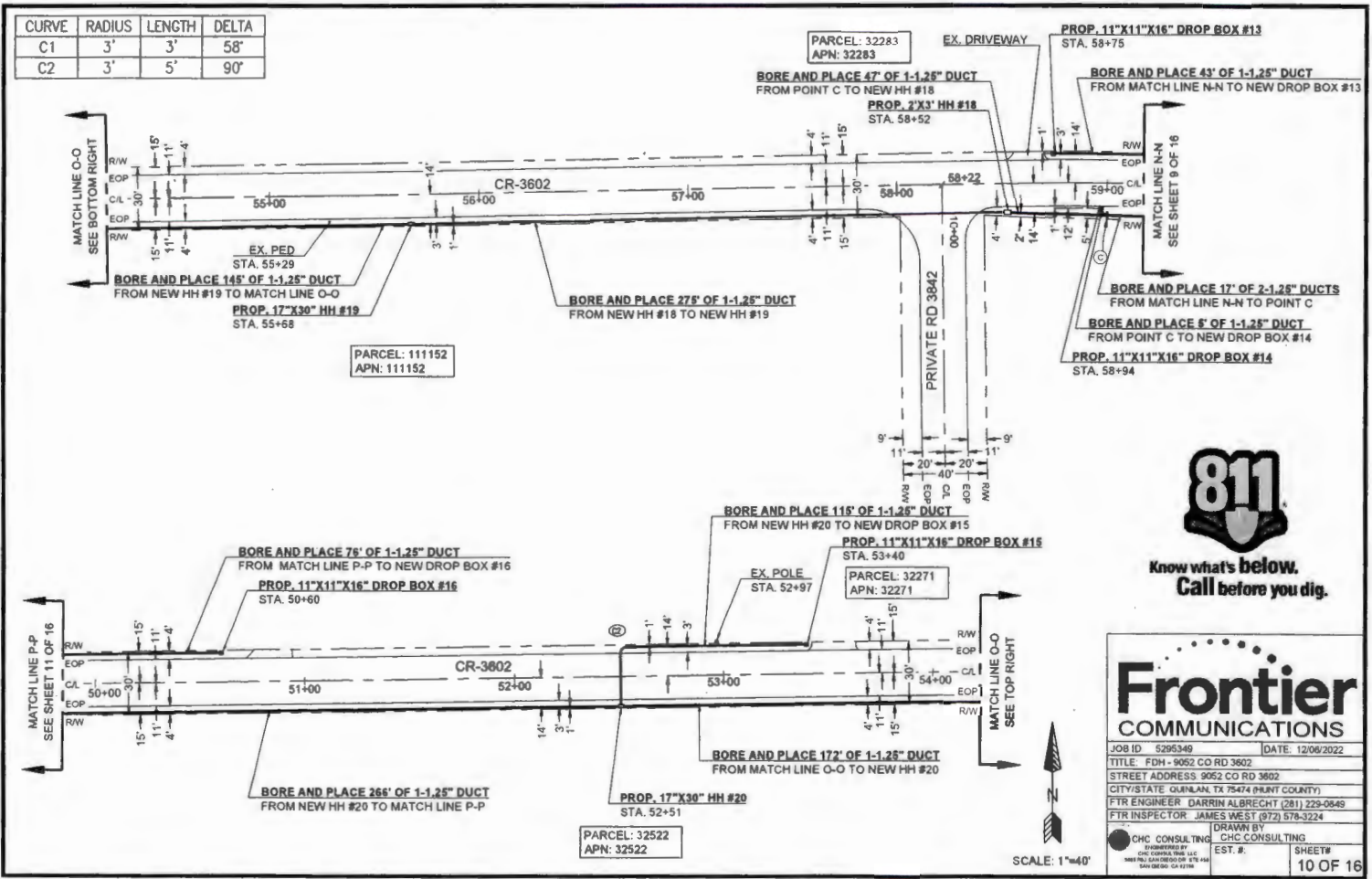

Know what's below.  
Call before you dig.

**Frontier COMMUNICATIONS**

JOB ID: 5295349      DATE: 12/06/2022  
 TITLE: FDH - 9052 CO RD 3602  
 STREET ADDRESS: 9052 CO RD 3602  
 CITY/STATE: QUANLAN, TX 75474 (HUNT COUNTY)  
 FTR ENGINEER: DARRIN ALBRECHT (281) 229-0849  
 FTR INSPECTOR: JAMES WEST (872) 578-3224

DRAWN BY: CHC CONSULTING  
 EST. #: CHC CONSULTING  
 SHEETS: 10 OF 16

SCALE: 1"=40'

CURVE	RADIUS	LENGTH	DELTA
C1	3'	4'	80'

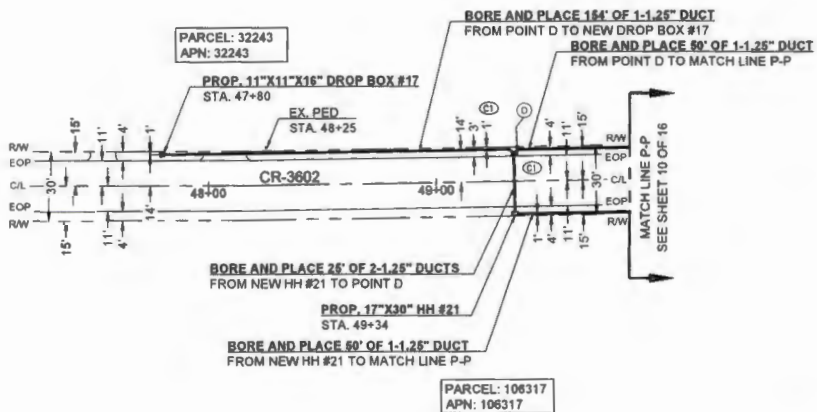

Know what's below.  
Call before you dig.

**Frontier COMMUNICATIONS**

JOB ID	5295349	DATE	12/06/2022
TITLE	FDH - 9052 CO RD 3602		
STREET ADDRESS	9052 CO RD 3602		
CITY/STATE	QUINLAN TX 75474 (HUNT COUNTY)		
FTR ENGINEER	DARRIN ALBRECHT (281) 229-0849		
FTR INSPECTOR	JAMES WEST (972) 578-3224		
DRAWN BY	CHC CONSULTING		
EST. #		SHEET #	11 OF 16

CHC CONSULTING  
ENGINEERING &  
CONSTRUCTION, LLC  
1000 SANDHILL DR. STE 100  
DALLAS TX 75243







MATCH LINE R-R  
SEE SHEET 12 OF 16

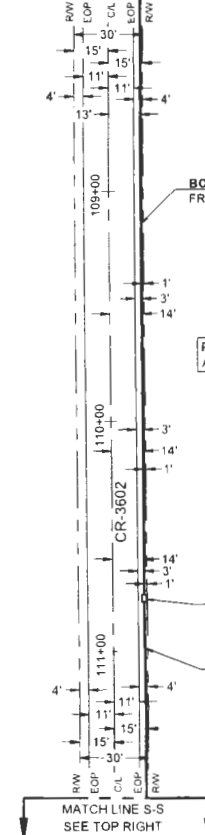

BORE AND PLACE 260' OF 2-1.25" DUCTS  
FROM MATCH LINE R-R TO NEW HH #25

PARCEL: 229605  
APN: 229605

PROP. 2'X3' HH #25  
STA. 110+28

BORE AND PLACE 85' OF 2-1.25" DUCTS  
FROM NEW HH #25 TO MATCH LINE S-S

MATCH LINE S-S  
SEE TOP RIGHT

MATCH LINE S-S  
SEE BOTTOM LEFT

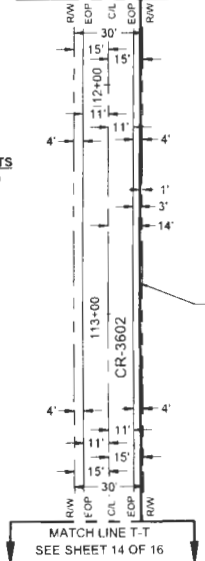

BORE AND PLACE 227' OF 2-1.25" DUCTS  
FROM MATCH LINE S-S TO MATCH LINE T-T

PARCEL: 229606  
APN: 229606

MATCH LINE T-T  
SEE SHEET 14 OF 16



Know what's below.  
Call before you dig.

SCALE: 1"=40'



# Frontier COMMUNICATIONS

JOB ID: 5295349 DATE: 12/06/2022  
 TITLE: FDH - 9052 CO RD 3602  
 STREET ADDRESS: 9052 CO RD 3602  
 CITY/STATE: QUINLAN, TX 75474 (HUNT COUNTY)  
 FTR ENGINEER: DARRIN ALBRECHT (281) 229-0849  
 FTR INSPECTOR: JAMES WEST (972) 578-3224

 CHC CONSULTING <small>1031 HWY. 400 (SUITE 310) F.W. TX 75001        972.578.3224 FAX 972.578.3224</small>	DRAWN BY CHC CONSULTING EST. #	SHEETS 13 OF 16

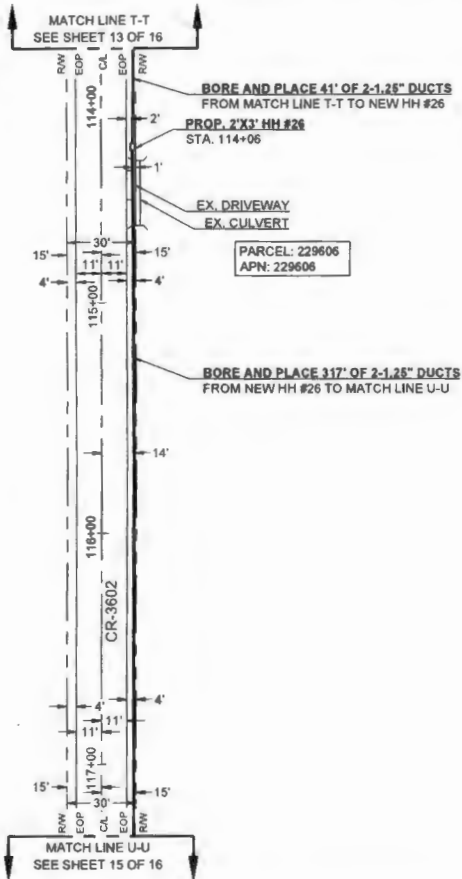

Know what's below.  
Call before you dig.

**Frontier COMMUNICATIONS**

JOB ID: 5295349	DATE: 12/06/2022
TITLE: FDH - 9052 CO RD 3602	
STREET ADDRESS: 9052 CO RD 3602	
CITY/STATE: QUINLAN, TX 79474 (PLANT COUNTY)	
FTR ENGINEER: DARRIN ALBRECHT (281) 229-0849	
FTR INSPECTOR: JAMES WEST (972) 578-3224	
DRAWN BY: CHC CONSULTING	
EST. #	SHEET #
	14 OF 16

CHC CONSULTING  
ENGINEERED BY  
CHC CONSULTING, L.L.C.  
1400 PCH DR. SUITE 100  
SAN DIEGO, CA 92108

MATCH LINE U-U  
SEE SHEET 14 OF 16

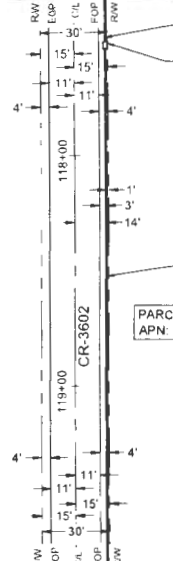

PARCEL 229604  
APN: 229604

MATCH LINE V-V  
SEE BOTTOM LEFT

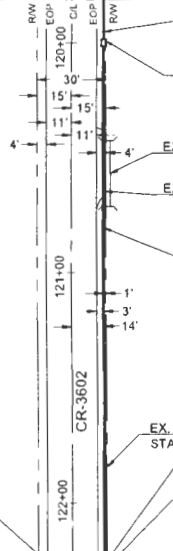

PARCEL 130488  
APN: 130488

WORK EXTENDS BEYOND TXDOT ROW

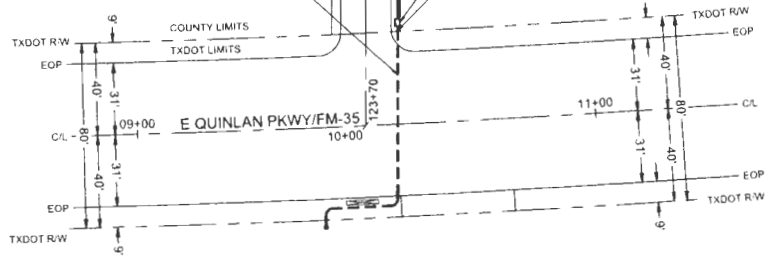

Know what's below.  
Call before you dig.



SCALE 1"=40'

**Frontier COMMUNICATIONS**

JOB ID: 5295349	DATE: 12/06/2022
TITLE: FDH - 9052 CO RD 3602	
STREET ADDRESS: 9052 CO RD 3602	
CITY/STATE: GUNLAN TX 75474 (HUNT COUNTY)	
FTR ENGINEER: DARRIN ALBRECHT (281) 229-0849	
FTR INSPECTOR: JAMES WEST (972) 578-3224	
CHC CONSULTING 1100 W. WILSON BLVD. SUITE 100 DALLAS, TX 75207	DRAWN BY: CHC CONSULTING EST. # SHEET # 15 OF 16

MINIMUM STANDARDS FOR DIRECTIONAL BORING

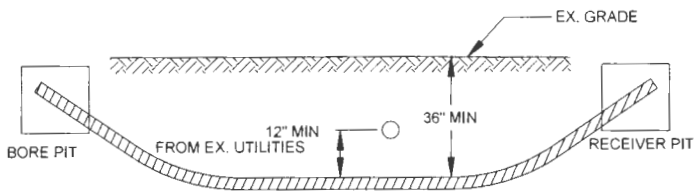

- PLACE END MARKER WITH UTILITY OWNER'S NAME DESCRIBING CONDUIT
- BORE PIT TO BE BACKFILLED AND COMPACTED IN 12" LIFTS WITH MATERIAL REMOVED
- FLOW OF DITCH MUST BE MAINTAINED AT ALL TIMES
- PROTECT ROOTS AT ALL TREE LOCATIONS. SHIFT BORE TRENCH IF NECESSARY

TYPICAL BORE DETAIL

SCALE  
N.T.S. 1

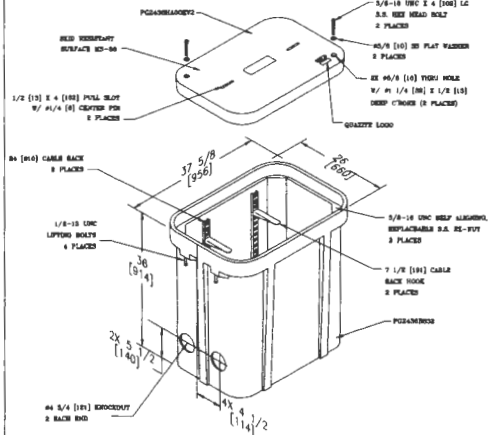

2' X 3' HAND HOLE

SCALE  
N.T.S. 2

**Frontier COMMUNICATIONS**

JOB ID: 5295349      DATE: 12/06/2022

TITLE: FDH - 9052 CORD 3602

STREET ADDRESS: 9052 CO RD 3602

CITY/STATE: QUINLAN TX 75474 (HUNT COUNTY)

FTR ENGINEER: DARRIN ALBRECHT (281) 229-0849

FTR INSPECTOR: JAMES WEST (972) 578-3224

DRAWN BY: CHC CONSULTING

EST. #      SHEET #

CHC CONSULTING  
 11110 LAMAR BLVD STE 110  
 DALLAS, TX 75243  
 TEL: 972-412-1111  
 FAX: 972-412-1112

16 OF 16

18,623-11



FILED FOR RECORD  
at 2:00 o'clock P M

FEB 13 2024

BECKY LANDRUM  
County Clerk, Hunt County, Tex.  
By

01/30/2024  
Pearce Services  
1222 Vine St., Ste 301  
Paso Robles, CA 93446

**Bore/Duct Installation/HH AND DB PL**

Greetings,

Frontier Communications is requesting permission to bore and place 864' of (1)-1.25" duct, place (2) 17"X30" HH, and (2) 11"X11"X16" drop box. This request is for road crossings on Beverly Drive. **Project # 5295349** (SR-352346).

Please, see the attached construction package for location and proposed work details. If you have any questions, please contact me at any time.

Sincerely,

Darrin Albrecht  
Manager, FTTH Quality Control  
Central Region  
Darrin.l.albrecht@ftr.com  
281-229-0849

Submitted by:  
Rodney Doyal  
Permit Specialist, Pearce Services  
rodney.doyal@pearce-services.com

*County Approval Section:*

Approved: \_\_\_\_\_

Denied: \_\_\_\_\_

Authorized Signature: \_\_\_\_\_ Date: \_\_\_\_\_

**FRONTIER COMMUNICATION  
CONSTRUCTION SPECIFICATIONS**

- Contact Frontier Engineer DARRIN ALBRECHT at (281) 229-0849 sixty (60) days prior to need of service in order to confirm compliance, order materials, and schedule work forces. NOTE: FRONTIER COMMUNICATIONS, INCORPORATED, RESERVES THE RIGHT TO REFUSE ANY CONDUIT, PULL BOXES, MANHOLES, OR UTILITY BOXES THAT DEVIATE FROM PLANS AND SPECIFICATIONS.
- All conduit clear bends to have a minimum thirty-six (36) inch radius.
- All horizontal ninety (90) degree bends shall have a minimum radius of 12.5 feet and all vertical ninety (90) degree bends shall have a minimum radius of three feet. No more than two ninety (90) degree horizontal bends shall be placed in any single run unless otherwise specified. Contact the Frontier engineer concerning any required deviations.
- All conduit must be proven using a mandrel no less than a 1/2" smaller than the conduit placed. Wall to wall measurements must be taken with a measured tape and a 3/8" polypropylene pull rope in each duct. An accurate wall to wall measurement of conduit placed must be As-built on an approved Frontier construction plan. A copy of the As-built conduit work order must be provided to the Frontier Inspector assigned to your project.
- Place weatherproof caps on all terminated conduits.
- Approved plastic conduit (PVC Sch. 40, TYPE-C or HDPE (2") is to be used in underground construction unless otherwise specified.
- Conduit terminated on a pole must be PVC Sch. 80. Location of riser on pole will be called out by engineering on the construction plan.
- Conduit placed in same trench with primary power conduit must be separated by a minimum of twelve (12) inches of well-packed sand or three inches of concrete, and have a minimum of thirty-six (36) inches of cover when placed behind curb face. All street crossings and conduits placed in the driven portion of the roadway must have a minimum of forty-eight (48) inches of cover to top of pipe. CONTACT THE FRONTIER INSPECTOR 48 HOURS BEFORE TRENCHING AND UPON COMPLETION OF YOUR SUBSTRUCTURES TO SCHEDULE THE FINAL INSPECTION.

**PERMITTING AGENCY:  
HUNT COUNTY  
(BEVERLY DR)**

**PICK UP POINT:** TXDOT LIMITS  
**PATH FOOTAGE:** SORE = 864'  
**MATERIALS:**  
(2) NEW 17"X20" HH  
(2) NEW 11"X11"X18" DROP BOX  
864' OF (1)-1.25" DUCT



**Know what's below.  
Call before you dig.**

**CONSTRUCTION PACKAGE**

**FDH - 9052 CO RD 3602  
BEVERLY DR & FM-751  
QUINLAN, TX 75474**

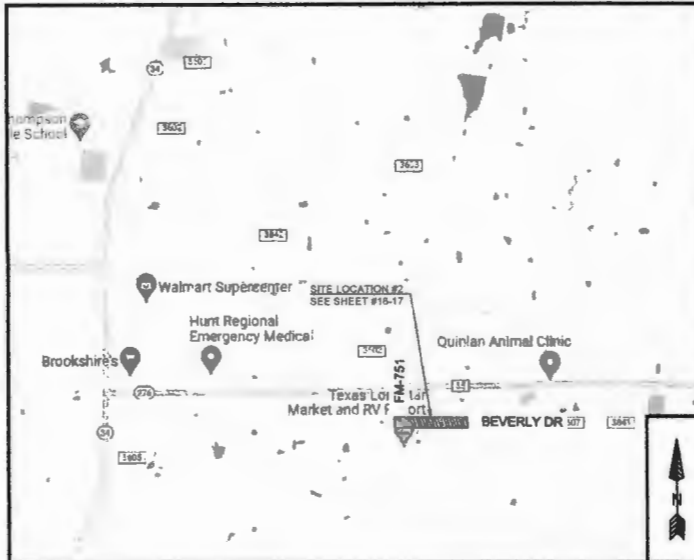

VICINITY MAP  
NTS

-HDPE AND PVC FOOTAGES DO NOT INCLUDE SWEEPS  
-ACTUAL FOOTAGES OF HDPE AND PVC WILL BE NEEDED TO ORDER MATERIALS. PLEASE INCLUDE MEASURED TAPE IN ALL PVC'S.  
-FRONTIER INSPECTOR SHALL BE PRESENT ON SITE WHEN CONTRACTOR NEEDS TO ACCESS ANY EXISTING FRONTIER FACILITY.

**ABBREVIATIONS**

BLDG	BUILDING	PED	PEDESTAL (UTILITY)
CL	CENTER LINE	PVC	POLYVINYL CHLORIDE
CONC	CONCRETE	PL	PROPERTY LINE
CSW	CONCRETE SIDEWALK	RR	RAILROAD
DWY	DRIVEWAY	RAW	RIGHT OF WAY
EOC	EDGE OF CURB	SL	STREET LIGHT
EOP	EDGE OF PAVEMENT	W-BLDG	WALL TO BUILDING
ETW	ETW LINE	W-P	WALL TO POLE
HH	HANDHOLE	W-W	WALL TO WALL
MH	MANHOLE	P.U.E.	PUBLIC UTILITY EASEMENT
NTS	NOT TO SCALE	P.S.E.	PUBLIC SERVICE EASEMENT
		CG	CURB & GUTTER

**LEGEND**

	New Trench
	New Box
	Existing Gas
	Existing Water
	Existing Telephone
	Existing Sewer
	Existing Storm Drain
	Existing Electric
	Existing Manhole
	Existing Handhole (2'x2' or 17'x30')
	DRAIN
	3-CORNER
	POWER PEDESTAL
	TELECO PEDESTAL
	2' X 5' PULL BOX
	POLE

**Frontier COMMUNICATIONS**

JOB ID: 5295349	DATE: 12/06/2022
TITLE: FDH - 9052 CO RD 3602	
STREET ADDRESS: 9052 CO RD 3602	
CITY/STATE: QUINLAN, TX 75474 (HUNT COUNTY)	
FTR ENGINEER: DARRIN ALBRECHT (281) 229-0849	
FTR INSPECTOR: JAMES WEST (972) 578-3224	
CHC CONSULTING	DRAWN BY
EST. #	SHEET#
	1 OF 4

CURVE	RADIUS	LENGTH	DELTA
C1	3'	5'	90°

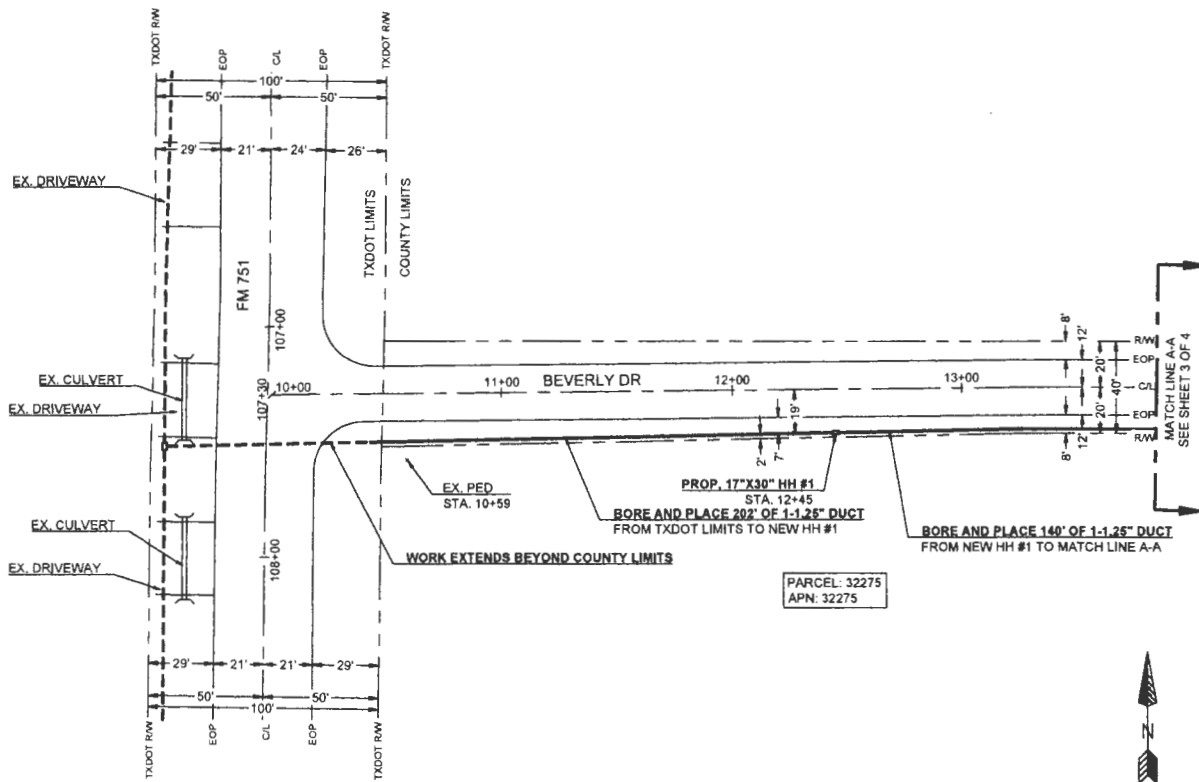

Know what's below.  
Call before you dig.

**Frontier COMMUNICATIONS**

JOB ID: 5295349      DATE: 12/08/2022

TITLE: FDH - 9052 CO RD 3602

STREET ADDRESS: 9052 CO RD 3602

CITY/STATE: QUINLAN, TX 75474 (HUNT COUNTY)

FTR ENGINEER: DARRIN ALBRECHT (281) 229-0849

FTR INSPECTOR: JAMES WEST (972) 578-3224

DESIGNED BY: CHC CONSULTING

DRAWN BY: CHC CONSULTING

EST. #:

SHEET #

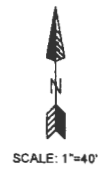



PARCEL: 32215  
APN: 32215

PARCEL: 32275  
APN: 32275

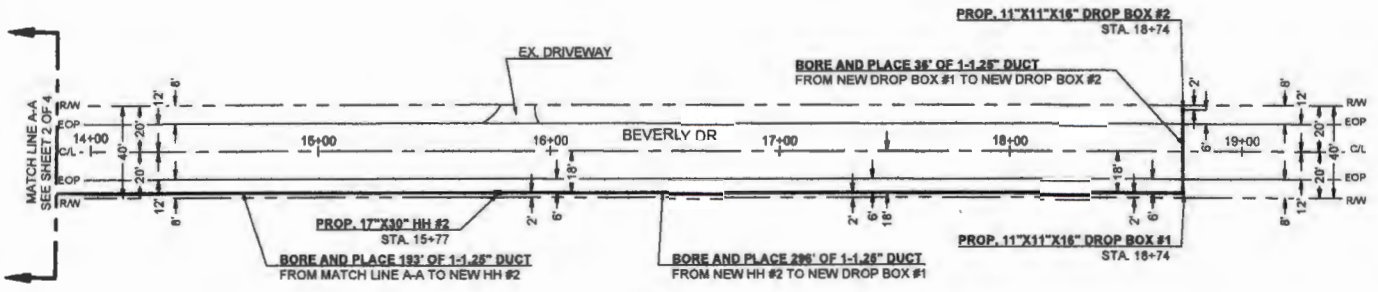

Know what's below.  
Call before you dig.

CURVE	RADIUS	LENGTH	DELTA
C1	3'	3'	58°



SCALE: 1"=40'

**Frontier COMMUNICATIONS**

JOB ID: 5295349 | DATE: 12/09/2022

TITLE: FDH - 9052 CO RD 3602

STREET ADDRESS: 9052 CO RD 3602

CITY/STATE: QUINLAN, TX 76474 (HUNT COUNTY)

FTR ENGINEER: DARRIN ALBRECHT (281) 229-0849

FTR INSPECTOR: JAMES WEST (872) 575-3224

DRAWN BY: CHC CONSULTING

EST. #:

SHEET# 3 OF 4

MINIMUM STANDARDS FOR DIRECTIONAL BORING

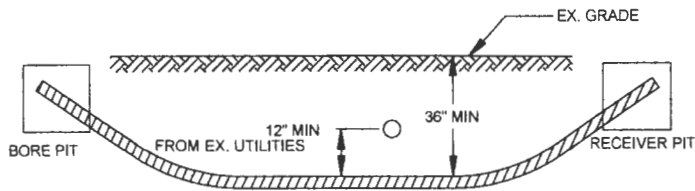

- PLACE END MARKER WITH UTILITY OWNER'S NAME DESCRIBING CONDUIT
- BORE PIT TO BE BACKFILLED AND COMPACTED IN 12" LIFTS WITH MATERIAL REMOVED
- FLOW OF DITCH MUST BE MAINTAINED AT ALL TIMES
- PROTECT ROOTS AT ALL TREE LOCATIONS, SHIFT BORE TRENCH IF NECESSARY

TYPICAL BORE DETAIL

SCALE  
N.T.S. 1

**Frontier**  
COMMUNICATIONS

JOB ID: 5295349	DATE: 12/06/2022
TITLE: FDH - 9052 CO RD 3602	
STREET ADDRESS: 9052 CO RD 3602	
CITY/STATE: QUINLAN, TX 75474 (HUNT COUNTY)	
FTR ENGINEER: DARRIN ALBRECHT (281) 229-0849	
FTR INSPECTOR: JAMES WEST (972) 578-3224	
DRAWN BY:	
<p>CHC CONSULTING EST. #:</p>	<p>CHC CONSULTING SHEET #:</p>
4 OF 4	



18,623-12

One Global Telecom, Inc  
24 Decker Ct  
Wylie, TX 75098

FILED FOR RECORD 972-442-1970  
at 2:00 o'clock P M

FEB 13 2024

Underground Facility Installation

BECKY LANDRUM

01/08/24

County Clerk, Hunt County, Tex.

Project ID 4698035

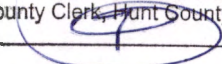
By 

One Global Telecom is requesting permission to install telecommunications facilities on behalf of Charter Communications utilizing existing conduit from the northwest corner of intersection of CR4208 and CR4209, running east along the north side of CR4209, as shown in the attached plans.

Site location map and permit exhibit are enclosed. The permit exhibit details the proposed work. If you have any questions, please contact me at any time. Additional contacts are Construction Managers Nick Mallory 469-418-2134 [nmallory@oneglobaltele.com](mailto:nmallory@oneglobaltele.com) and Mason Reeder 469-261-5388 [mreeder@oneglobaltele.com](mailto:mreeder@oneglobaltele.com).

Sincerely,  
Austin Rose  
Project Manager  
[arose@oneglobaltele.com](mailto:arose@oneglobaltele.com)  
903-366-2471

County Approval Section

Approved: \_\_\_\_\_ Denied: \_\_\_\_\_

Authorized Signature: \_\_\_\_\_

Date: \_\_\_\_\_

Project Information

CHARTER COMMUNICATIONS CONSTRUCTION SURVEY			
<small>Version 3.2 1/25/2021</small>			
<b>Grey Fields are Mandatory for Enterprise and SMB projects</b>			
<b>Project Information</b>			
Project Name: COOPER, CHRISTOPHER			
Address: 2064 COUNTY ROAD 4208 CAMPBELL, TX 75422			
Map Number:			
Project Specific Statement of Work: <small>(required if ROE is needed)</small>			
PRISM ID: 4698035			
Date of Survey: 12/27/2023			
Specialty Products:			
Surveyed by: Bob Zingaro			
Competitive Presence			
Length of Building			
Width of Building			
Number of Stories			
Building Exterior Finish			
Common MPOE Available <small>if "Yes", Populate the MPOE Checklist tab</small>			
Prebury Drop			
Number of units in building			
Service drop length			
Fiber Verification Completed by			
Fiber Verification Complete Date			
		<b>Building Access Information</b>	
		Name	
		Phone Number	
		After Hours	
		Emergency	
<b>Fields below are Optional not Mandatory</b>			
<b>Construction Passings</b>			
Projected Passings		Vacant Lots Passed	
Actual Home Passes			
<b>Composite Footage</b>			
Aerial Footage		UG Footage	
<b>Detail Footage</b>			
<b>Survey Cables</b>		<b>Survey Fiber</b>	
Aerial Footage		Aerial Footage	
Aerial Overlash		Aerial Overlash	
UG Footage		UG Footage	
Trench		Trench	
Bore		Bore	
Pull Thru		Pull Thru	
Bldg Attachment		Bldg Attachment	
Direct Bury		Direct Bury	
UG Occupied		UG Occupied	
AE Rework Existing		AE Rework Existing	
UG Rework Existing		UG Rework Existing	
AE Removed		AE Removed	
		<b>Survey Other</b>	
		Aerial Vacant Strand	
		New Aerial Strand	
		Vacant Structure	
		New Vacant Structure	
		Removed Direct Bury	
		Drop	

Field Map

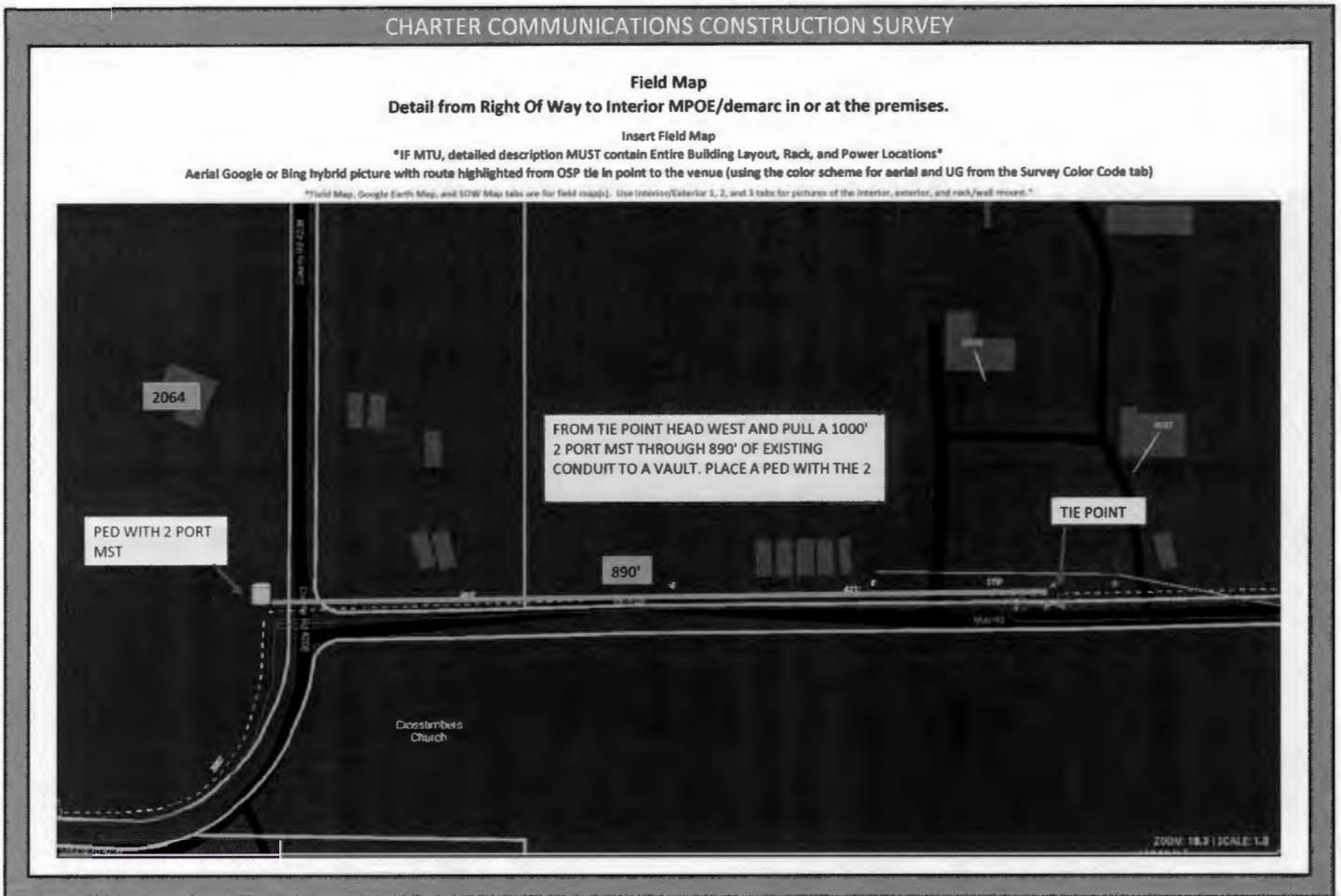

Google Earth Map



SOW Map

CHARTER COMMUNICATIONS CONSTRUCTION SURVEY

**Statement of Work (SOW) Map & Details**  
**Detail from Right Of Way to Interior MPOE/demarc in or at the premises.**

Insert SOW Map & Details

A SOW must include a detailed map, Google Earth and/or ground level pictures or layout, and a detailed description of what work will be done that can be presented to the owner to detail what work will happen/occur on their property, as in building entry, or any other kind of disturbance to their property, while showing the physical route of Charter's proposed plant. When needed, SOW information is used to help in obtaining an ROE (Right of Entry).



Interior Exterior 1

CHARTER COMMUNICATIONS CONSTRUCTION SURVEY

Insert Exterior & Interior Pictures  
Include Rack or Wall Mount Pictures



EXTRA DETAIL



EXTRA DETAIL



Insert pic here





Measure distance ✕  
Click on the map to add to your path  
Total distance: 889.76 ft (271.20 m)

**Survey Info**

FRM ID:	022825 - Blue - New - C2	Originator:	BRO Billing Integration	Business/Company Name:	COOPER/CHRISTOPHER
Construction Type:	Residential Serviceability	Coord Supervisor:	Joneski, John	Address:	2884 COUNTY ROAD 488
Process Stage:	CA - Funding Approved	Construction Coordinator:	Ziegler, Bob B (P2148841) - p2148841	City/State/Zip:	CAMPBELL, TX 75432
Project Status:	In Progress	Total Project Cost:	2863.87	Cross Street:	
Input Date:	06/17/23	Total Pavement:	1	Prop Det Status:	
Hub:	99 - GARRETTVILLE-TX	Service Bv Cr:	620424	Cost: RA:	Plan: Yes
Node:	5079E - 5079E	Entity:	1002	Construction Survey Completed:	Yes
Construction Det Date:		Priority Class:		Construction Sub Type:	BAU

**Project Design**

CPR ID:	0801120	Management Area:	TRI-North Texas
Entity:	1983-North Texas-TX	Services from Survey:	
Map Ord:	Lot: 33 Ord: 37 S: C: N: Loop: 82 Ord: 54 S: W	Only Available Bv Date:	6/29/2024
Project Approved Date:	12/29/2023	Node Capacity:	
Construction Sub Type:	BAU	Special Inlet(s):	

Design Link  Man Station

Design Number: 0801120

**NODE: 5079E**  
**MAP: 33.181825,-95.909395**  
**AFTER PRINT**  
**INSTANCE: TWNTX**

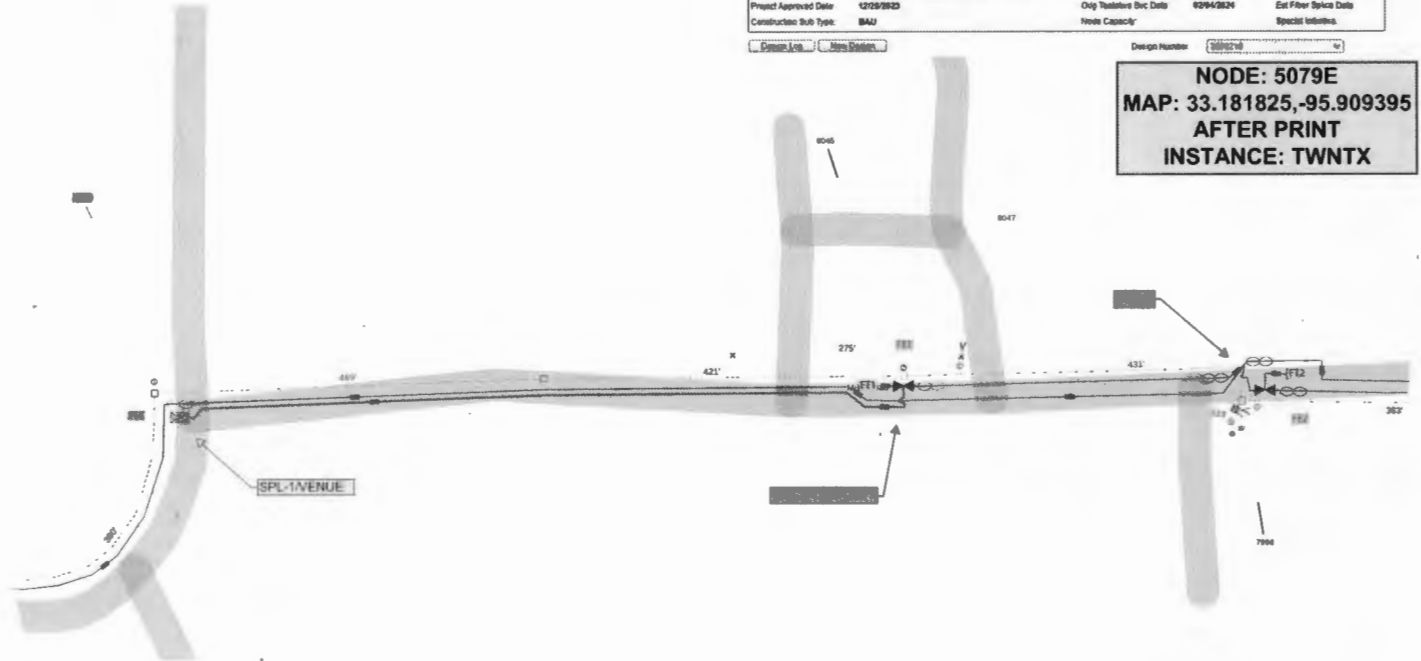

**FIBER EQUIPMENT**

TAG	NAME	MFG	MODEL	OPTICAL SPLITTERS
FE1	NTX5079D017	COMMSCOPE	FTTX_CO_450B48_SPL_DIST	
FE2	NTX5079D018	COMMSCOPE	FTTX_CO_450B48_SPL_DIST	

**FIBER TERMINATION POINTS**

TAG	NAME	MFG	MODEL	PORT COUNT	OPTICAL SPLITTERS
FT1	NTX50790001	AMPHENOL	FTTX_CL_U_02_SMST	2	
FT2	NTX50790002	AMPHENOL	FTTX_CL_U_02_SMST	2	
FT3	NTX50790088	COMMSCOPE	FTTX_CO_U_02_MH_HMST	2	